

# LIEBHERR R9250 RISER DETACHMENT FAILURE AT GLENCORE MANGOOLA MINE



Circulation: Restricted to Nominated Officers

Report No: MTI/DS/694

Revision: Rev 0

Date Issued: 25<sup>th</sup> September 2019

## DOCUMENT CONTROL

<b>Maintenance Technology Institute</b> Department of Mechanical and Aerospace Engineering Monash University (Clayton Campus) PO Box 31 Clayton, Victoria 3800, Australia Telephone: +61 3 9903 1985 Facsimile: + 61 3 9903 2076 <a href="http://www.eng.monash.edu.au/mti/">http://www.eng.monash.edu.au/mti/</a>	Document No:	MTI/DS/693
	Title:	Liebherr R9250 Riser Detachment Failure at Glencore Mangoola Mine
	Client:	Glencore Mangoola Mine

### Document History:

Revision	Date Issued	Author/s	Reviewed by	Approved by	Comments
0	25 <sup>th</sup> September 2019	Daya Dayawansa, Amanda Gonzago and Michael Lo	Tony Carpinteri	Gerard Chitty	

## DISCLOSURE NOTICE

**(Please read before reading report)**

### **PURPOSE:**

This report describes the details of the investigation undertaken by MTI regarding the Liebherr R9250 cab and riser detachment from chassis due to attachment bolt failure. The main purpose of the investigation was to determine the root cause(s) for the failure and to develop a comprehensive risk management strategy to prevent similar failures at not only Mangoola mine but also mining industry wide.

### **AUDIENCE:**

This report is intended to Glencore and Mangoola staff only. Supply of the report to persons or organizations other than Glencore and Mangoola Mine staff is strictly on the basis of mutual agreement between management of Glencore and MTI. Although general recommendations based on the evidence available and the analysis undertaken by MTI are given in the report, the authors, accept no responsibility for the application of any part or whole of the contents of the report by any other party. The total responsibility and liability for any such application or adaptation of the recommendations given in the report shall remain solely with the parties who use the report.

### **ASSUMPTIONS/QUALIFICATIONS:**

The investigation done by MTI is based on the information provided by Mangoola Mine in the form of: previously undertaken failure investigation reports; maintenance practices used; etc and the structural details and other information of the machine provided by the OEM Liebherr. These data supplied by Mangoola and the OEM are accepted in good faith and in the context they have been provided. Since this investigation is undertaken a considerable time after the failure, MTI had no opportunity to visit the site and make their own observation at the time of the failure.

### **EXTERNAL SOURCE MATERIALS:**

MTI and/or Monash University do not accept liability for the accuracy of source material and data not generated by MTI, which is used in the present work.

Maintenance Technology Institute

Department of Mechanical Engineering

**Monash University (Clayton Campus)**

22 Alliance Lane, Clayton

Victoria, Australia 3800

PO Box 31, Clayton, Victoria, Australia 3800

Telephone: +61 3 9903 1985 Facsimile: +61 3 9903 2076

<http://www.eng.monash.edu.au/mti/>

## EXECUTIVE SUMMARY

On the 10th October 2016, during normal coaling operations, the riser and the cabin of Liebherr R9250 Excavator (EX151) operating at Glencore Mangoola mine, separated from the chassis together as a unit, and tipped over to the side of the machine. ICAM investigation was undertaken by Glencore Mangoola and a failure investigation on the two last failed bolts was undertaken by Bureau Veritas (BV).

Mangoola Mine commissioned MTI in latter part of 2018 to undertake a detailed and independent investigation of the failure, and to provide recommendations to prevent similar failures occurring in the future.

The MTI investigation consisted of: (i) review of all available material related to the failure; (ii) instrumentation and monitoring the operations of the machine; (iii) theoretical analysis and FE modelling to understand the behaviour of the riser attachments; and (iv) fatigue assessments using measurements and analysis.

MTI's Structural Monitoring System (SMS) and additional instrumentation including instrumented bolts, accelerometers and displacement measurements were installed to record data during normal operations and by conducting specific tests.

The following conclusion can be made from the investigation

The ICAM report identified two main root causes: (i) misalignment between the riser and the chassis mounts; (ii) failure of the design and monitoring program to detecting the failing state of the interim repair.

Out of the total six bolts connecting the cab riser to chassis, four bolts had broken over a period of time. Some additional strengthening had been done to compensate for the four missing bolts, as the broken bolts could not be replaced without complete removal of the cab riser assembly. At the time of the final failure, the riser was attached with one horizontal bolt and one vertical bolt only.

The contents of the BV bolt failure report, combined with the MTI measurements and analysis, concluded the following:

- (i) Both failed bolts BV examined had signs of fatigue at the failure cross sections.
- (ii) The bolt material complied with the strength grade of Grade 10.9 specified by the OEM. Therefore, bolts provided the intended strength to the connection.
- (iii) Significant thread indentation marks on the bore of the riser attachment blocks were reported which were 35 mm diameter compared to the bolt diameter of 30 mm. These indentation marks were present even in the bore of the very first bolt that failed. This clearly showed that the riser was moving with respect to the chassis in the order of at least 2-3 mm even when all six bolts were in place. MTI measurements also found similar relative movement even after all the bolts were newly replaced and tightened to the OEM specification.
- (iv) Both bolts had failed at the riser and chassis interface of the attachment where bending stresses are maximum.

The following conclusions can be summarised from the MTI investigation:

- (i) The pretension of the instrumented bolts at installation showed:
  - Significant variation in pretension in each bolt.
  - Not all bolts achieved the OEM recommended pretension.



- Currently the pretension is set to 57% of proof stress, which is low compared to industry practice.
  - Procedure to achieve recommended pretension of bolts was not provided by the OEM.
  - The theoretical connection analysis undertaken showed that the bolts can be exposed to higher levels of fatigue loading when the pretensions are low.
- (ii) Sudden application of vertical force with side force causes significant force/stress spikes in the excavator structure and the cab riser connection bolts. These also cause high relative movement between the cab riser and the chassis.
  - (iii) Analysis of SMS data indicates periods with high fatigue life usage which coincide with periods where the machine was digging coal. These operating conditions and operator practices have a large influence on the life of the bolts.
  - (iv) The movement of the cab riser relative to the chassis with the current bolt connection design cause bolts to experience significant bending during operations, which significantly lower the life of the bolts.
  - (v) The FEA of the connection showed that bolts will develop significant bending moments at the failed cross section due to the relative movement.
  - (vi) The fatigue assessment of bolts showed that the component of fatigue damage due to bending is as high as 85% of the total damage. The maximum bending moment in bolts falls within the threaded part of the bolt; which experience high stress concentration effects due to the sharp geometry of the threads.
  - (vii) Another significant weakness in the riser attachment design is that if a bolt is broken, that bolt cannot be replaced unless the entire assembly of the riser and the cabin is removed.
  - (viii) Even if a bolt inspection scheme detects a crack in a bolt, the bolt could break when attempting to replace it. Therefore, a conservative bolt replacement scheme and a frequent ultrasonic testing (UT) scheme for bolts is needed.

The following recommendations can be made from the MTI investigation to improve the life of the attachment bolts and eliminate/minimise the risk of failure:

- (i) Pretensions of Bolts
  - All bolts should be pretensioned to the recommended value.
  - Consideration should be to increase pretension of the bolts only if bending of the bolts can be significantly reduced or prevented.
  - A pretensioning procedure to be introduced to include a bolt pretension sequence and a re-tightening process to ensure that all bolts achieve the specified correct pretension value at the end of the pretensioning sequence.
  - The pretensions should be checked at the next scheduled service day after installation to ensure any pretension losses are rectified.
- (ii) As the bolts experience bending with current connection detail, the bolts should be replaced every 5000 hrs prior to bolt crack initiation and UT inspections should be carried out every 3 months to detect any crack initiation, as it is impossible to replace a broken bolt without removing the entire riser.
- (iii) Inspect areas of the attachment block adjacent to the horizontal bolts every 5000 hours as cracks in these areas will lead to loss of pretension in the horizontal bolts.
- (iv) Conduct operator awareness training program to minimise/eliminate force/stress spike during operations. The SMS real-time feedback system should be utilised to minimise cumulative damage in the excavator and riser attachments, and improve productivity.

- (v) Operating conditions should be monitored using the SMS and the data be used to trigger inspections/replacement of bolts.
- (vi) Mangoola mine to ensure adequate ground preparations are carried out to minimise excessive force required by the machine operator to dig hard ground.
- (vii) The bolt connections between the riser and chassis should be redesigned to prevent movement of the riser with respect to the chassis which cause bending in the bolts. Alternatively, consideration should be given at least to use a bolt and nut arrangement where feasible to facilitate easy replacement of a bolt in case of a bolt failure.

## CONTENTS

<b>1</b>	<b>INTRODUCTION .....</b>	<b>1</b>
1.1	GENERAL.....	1
1.2	OBJECTIVES OF MTI INVESTIGATION .....	1
1.3	SCOPE OF MTI INVESTIGATION .....	2
<b>2</b>	<b>BACKGROUND INFORMATION.....</b>	<b>3</b>
2.1	DETAILS OF FAILURE.....	3
2.2	CHRONOLOGY PRIOR TO FINAL FAILURE.....	3
<b>3</b>	<b>MTI INVESTIGATION .....</b>	<b>6</b>
<b>4</b>	<b>PREVIOUS INVESTIGATIONS AND THEIR FINDINGS .....</b>	<b>7</b>
4.1	SUMMARY AND FINDINGS OF ICAM INVESTIGATION.....	7
4.1.1	<i>Key Finding of ICAM</i> .....	7
4.1.2	<i>Root Cause</i> .....	7
4.1.3	<i>Other Contributing Factors</i> .....	7
4.1.4	<i>Conclusions of ICAM Investigation</i> .....	8
4.1.5	<i>ICAM Recommendations</i> .....	9
4.2	SUMMARY AND FINDINGS OF BUREAU VERITAS BOLT INVESTIGATION .....	10
4.2.1	<i>Overview</i> .....	10
4.2.2	<i>Information Extracted from Report</i> .....	10
<b>5</b>	<b>INSTRUMENTATION AND MEASUREMENTS.....</b>	<b>16</b>
5.1	SMS INSTRUMENTATION.....	16
5.1.1	<i>Instrumentation of the Excavator Boom, Stick and Bucket</i> .....	16
5.1.2	<i>Instrumentation of the Cabin Riser</i> .....	16
5.2	TYPICAL DATA AND MAIN FEATURES .....	17
5.2.1	<i>Pretensions in Bolts</i> .....	17
5.2.2	<i>SMS Data</i> .....	18
<b>6</b>	<b>MODELLING AND ANALYSIS.....</b>	<b>21</b>
6.1	THEORETICAL MODELLING OF BOLTED CONNECTIONS .....	21
6.1.1	<i>Brief Literature Review</i> .....	21
6.1.2	<i>Analysis of Connection of Bolt D using [3]</i> .....	21
6.1.3	<i>Conclusions from Analysis</i> .....	24
6.2	FINITE ELEMENT MODELLING .....	25
6.2.1	<i>Bolt stress concentration factors</i> .....	25
6.2.2	<i>Cabin Riser</i> .....	26
<b>7</b>	<b>OVERALL ASSESSMENT.....</b>	<b>30</b>
7.1	INTRODUCTION.....	30
7.2	FATIGUE EXPECTATIONS UNDER CURRENT CONDITIONS .....	30
<b>8</b>	<b>IMPROVEMENT STRATEGIES .....</b>	<b>32</b>
8.1	POSSIBLE IMPROVEMENT OPPORTUNITIES - OPERATIONAL .....	32
8.2	POSSIBLE IMPROVEMENT OPPORTUNITIES – BOLTED CONNECTIONS.....	32
<b>9</b>	<b>CONCLUSIONS AND RECOMMENDATIONS .....</b>	<b>34</b>

<b>10</b>	<b>REFERENCES .....</b>	<b>38</b>
<b>11</b>	<b>APPENDIX .....</b>	<b>39</b>
11.1	SMS INSTRUMENTATION LOCATIONS .....	39
11.2	SMS 40 HZ DATA SAMPLES .....	44

## 1 INTRODUCTION

### 1.1 GENERAL

At approximately 8:45pm on the 10<sup>th</sup> October 2016, during normal coaling operations, the riser and the cabin of Liebherr R9250 Excavator (unit EX151) operating at Glencore Mangoola mine, separated from the chassis together as a unit, and tipped over to the side of the machine with the operator still inside the cabin, coming to rest against the tracks of the machine – see Figure 1-1 below. The Operator was unharmed in the incident and extricated safely by the ERT before being taken to First Aid for observation.

The main reason for the failure was the fracture of the bolts that attach the riser to the chassis. These bolts had failed in a sequence over a period of approximately 5 months leading to the final complete detachment of the riser from the chassis.

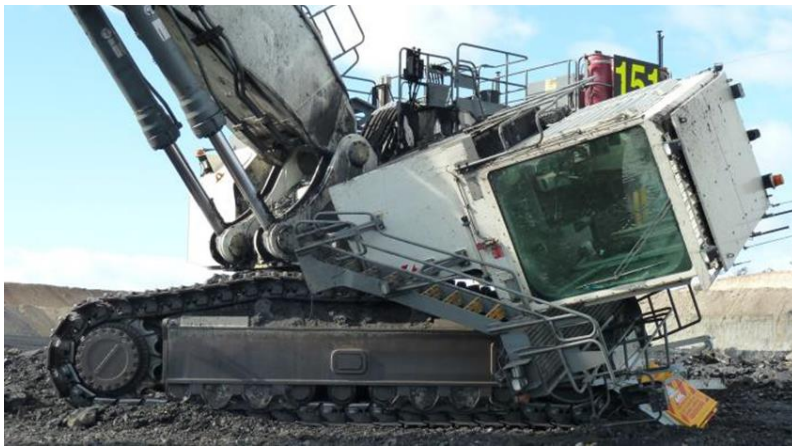

**Figure 1-1: Riser and Cabin Detachment of Liebherr R9250 Excavator (unit EX151) at Mangoola Mine**

Several investigations had been undertaken at the time to determine the root cause of the failure and to make recommendations to prevent similar failures in the future, and some of these were:

- (i) **ICAM Investigation** - The ICAM investigation team was commissioned and its investigation started on 12th October 2016 and completed the next day on 13th October 2016 [1].
- (ii) **Bureau Veritas** – BV undertook an investigation on the failed bolts [2].

Glencore commissioned MTI in 2018 to review all the available material and undertake a separate detailed investigation into the incident to develop comprehensive risk management strategy to prevent similar failures in the future. This report provides the details, the findings of the MTI investigation and recommendations for a comprehensive risk management strategy.

### 1.2 OBJECTIVES OF MTI INVESTIGATION

The main objectives of the investigation were to:

- (a) Determine the causes of failure of the excavator chassis and riser attachments through a detailed investigation that include:
  - Engineering analysis;
  - Measurement of stresses and other parameters during operations;
  - and
  - Fatigue life assessment of the relevant structural components using

FE analysis and measurements.

- (b) Develop and recommend strategies to prevent similar failures in the future.

Inform and educate the industry in general to prevent similar failures in the future. This will include presentations to the mine site personnel and industry in general.

### 1.3 SCOPE OF MTI INVESTIGATION

In consultation with appropriate stakeholders, review the incident, undertake a detailed assessment, and develop a report providing recommendations to assist in preventing a reoccurrence of the incident, including:

- (a) On the Liebherr 9250 excavator, undertake a vibration and stress monitoring program, engineering analysis and fatigue life assessment of the attachment bolts connecting the riser to the chassis to determine if any equipment operational factors, deficiencies of current system contributed to equipment structure failure.
- (b) Develop recommendations to:
- (i) Address the main cause or contributing factors of failure.
  - (ii) Repair or retrofit the cabin mountings with appropriate levels of structural integrity and safety factors.
  - (iii) Address any operator, maintenance, organisational or human factors that are found to have contributed to the incident.
  - (iv) Undertake a comprehensive risk management strategy for the industry to prevent similar failures, including:
    - Periodic maintenance inspections with clearly defined criteria to respond to any defects observed during inspections;
    - Periodic non-destructive testing; and
    - Ongoing stress and vibration measurements over a period to ensure safety of the repaired or retrofitted system of personnel interface attachments.
- (c) Once the report has been prepared, a legal review and assessment of the report and recommendations will be obtained to provide compliance mapping. Compliance mapping will identify relevant aspects of the health and safety legislation applicable to mines and will be able to be used to provide necessary guidance to the industry as to the key legal compliance considerations when undertaking similar activities.



## 2 BACKGROUND INFORMATION

### 2.1 DETAILS OF FAILURE

The chassis, the riser and the cabin general arrangement, including the positions of the mounting bolts, is shown in Figure 2-1. As seen in this figure, the riser is attached to the chassis with four vertical bolts and two horizontal bolts. The bolts are 30 mm diameter, 300 mm long, and Grade 10.9 bolts. The bolts pass through 100x100x250 mm blocks of steel (with 35 mm diameter holes for horizontal mounts and 33 mm diameter holes for vertical mounts) welded to the cabin and get threaded into tapped holes in the chassis. The cabin is separately mounted on top of the riser. The total weight of the cabin and the riser is ~9000 kg.

The sequence of bolt failures, as given in the incident report [1], is also shown in Figure 2-1. The sequence of failure given in [2] is slightly different.

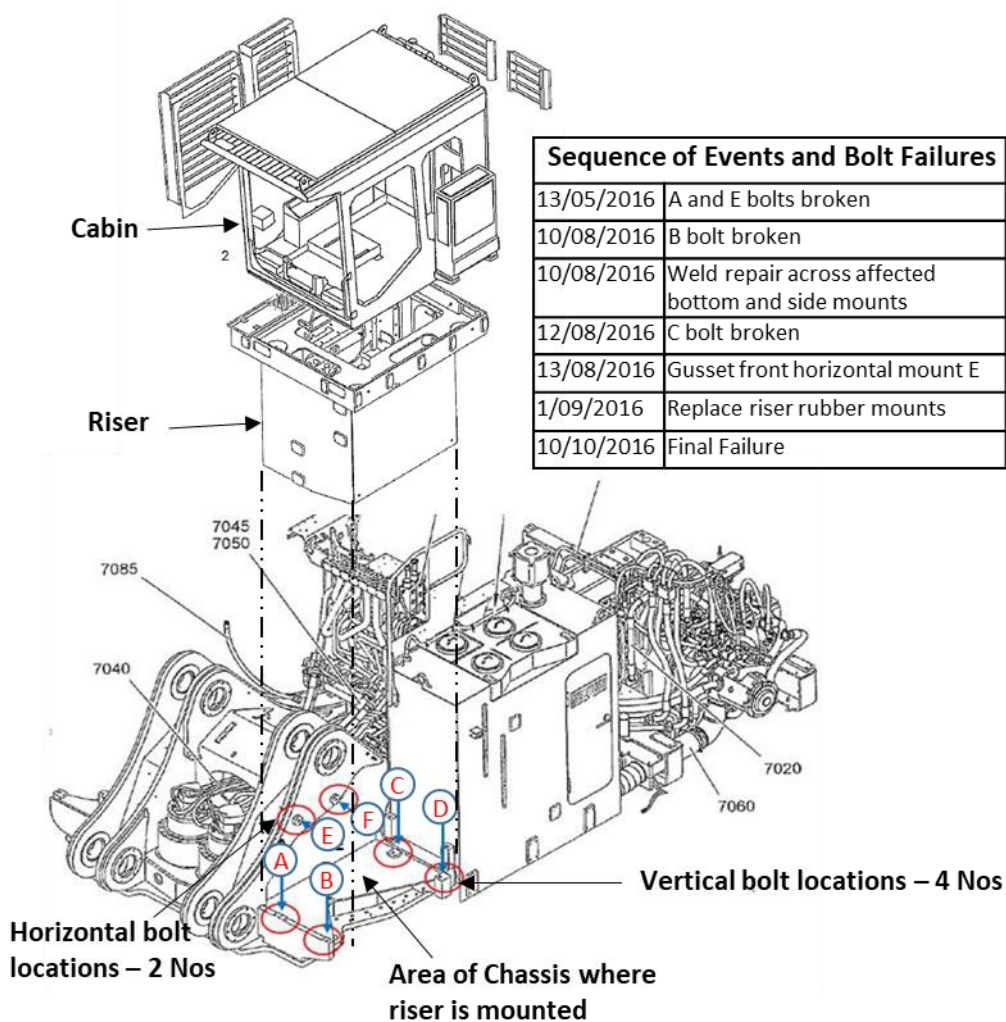

Figure 2-1: Chassis, Riser and Cabin General Arrangement

### 2.2 CHRONOLOGY PRIOR TO FINAL FAILURE

When the final failure occurred:

- (a) It was night time with adequate artificial lighting;

- (b) Good ground and work area (dry, slightly undulating coal, adequate work space);
- (c) Clear night (no rain or fog); and
- (d) Workers fatigue was considered but not deemed as a factor.

At the time of the incident, the machine had approximately 32,000 SMU hours on it with no previous faults reported on the cab riser bolts before the 13th of May 2016. The machine was commissioned on 26<sup>th</sup> November 2010.

Detailed account of the events preceding the final failure is given in Table 2-1 below. According to the information given in Table 2-1, the four broken bolts could not be properly replaced due to the inability of removing the broken bolt segments inside the tapped chassis holes without removing the entire cabin from the chassis. Therefore, some interim strengthening was undertaken to compensate for the broken bolts.

**Table 2-1: Detailed Account of Events Preceding Final Failure [2]**

Date (all dates occurred in 2016)	Event
13 <sup>th</sup> May	<ul style="list-style-type: none"> <li>▪ Two broken bolts identified during service (1 horizontal bolt “E” and 1 vertical bolt “A”)</li> </ul>
23 <sup>rd</sup> May	<ul style="list-style-type: none"> <li>▪ Work Order raised to replace with new bolts</li> <li>▪ Maintenance Planner contacted Liebherr (OEM) to advise of broken bolt and requests information of any history or known causes of broken bolts.</li> </ul>
21 <sup>st</sup> June	<ul style="list-style-type: none"> <li>▪ First attempt made to remove and replace bolts.</li> <li>▪ This was unsuccessful due to some misalignment and inability to effectively reach approx. 250mm to the broken part of the bolt.</li> </ul>
7 <sup>th</sup> July	<ul style="list-style-type: none"> <li>▪ Second unsuccessful attempt made to remove and replace broken bolts but same misalignment and inability to access the broken bolts were experienced as first attempt.</li> </ul>
10 <sup>th</sup> Aug	<ul style="list-style-type: none"> <li>▪ An additional (3<sup>rd</sup>) broken bolt identified during inspection (2<sup>nd</sup> vertical bolt “B”) Liebherr site rep notified of failure &amp; inspected machine on site with the Maintenance Step-up Supervisor.</li> <li>▪ Inspection and informal risk assessment/discussion was conducted involving Maintenance Superintendent, Maintenance Planner, Maintenance Step Up and Mining OCE to identify suitability and effectiveness of a potential interim repair for the purpose of securing the cab riser to the chassis. This repair was intended to be further reinforced on the 13th August.</li> <li>▪ MMS carried out interim repair to weld across the affected bottom &amp; side mounts. Although not welded on all sides due to access restrictions it was seen as necessary for additional reinforcement of the first weld repair. This repair was recognised as not a typical installation and hence the need for the inspection.</li> <li>▪ GCOM communication commenced from N/S 10<sup>th</sup> August to inform Maintenance Teams of interim repairs to EX151 and requirement to inspect and monitor repair and riser each shift during crib.</li> </ul>
11 <sup>th</sup> Aug	<ul style="list-style-type: none"> <li>▪ An incident occurred where a rock had rolled onto the track and made contact with the support under the cab riser. Maintenance inspected the area and reported no cause for concern.</li> </ul>
12 <sup>th</sup> Aug	<ul style="list-style-type: none"> <li>▪ Another (4<sup>th</sup>) broken bolt identified (3<sup>rd</sup> vertical bolt “C”) Informal risk assessment/discussion conducted between Maintenance Supt, Maintenance Planner and Mangoola Boilermaker to identify suitability and effectiveness of a modification to reinforce the current interim repair.</li> <li>▪ The group inspected EX151 and discussed options to reinforce the temporary weld. The group determined through application of knowledge and experience that adding gussets to the front</li> </ul>

	horizontal mount of bolt “E” would provide additional weld length and strength across the joint to provide effective reinforcement in the aim of conducting full repair to the cab riser mounts during the scheduled November Shutdown. It was the intention that the shift inspections would identify any deterioration of the interim repair in time to repair it before a catastrophic failure occurred.
13 <sup>th</sup> Aug	<ul style="list-style-type: none"> <li>▪ Further reinforcement to the interim repair carried out by Mangoola Boilermaker to secure front horizontal mount to boss with gussets.</li> </ul>
15 <sup>th</sup> Aug	<ul style="list-style-type: none"> <li>▪ Liebherr (OEM) representative documented cab riser broken bolt status and interim repair measures taken and entered into the Liebherr PIR System.</li> </ul>
1 <sup>st</sup> Sept	<ul style="list-style-type: none"> <li>▪ Cab to riser rubber mounts replaced as a further control measure to minimise movement.</li> </ul>
10 <sup>th</sup> Oct	<ul style="list-style-type: none"> <li>▪ At 8:45pm one of the two remaining cab riser bolts “F” or “D” failed causing overload on the remaining bolt and interim weld on “E” which have then failed OR the interim weld on “E” has failed causing overload on the remaining bolts “F” and “D” which resulted in the cab and riser tipping off the side of the machine.</li> </ul>

### 3 MTI INVESTIGATION

The MTI investigation was planned giving consideration to the evidence extracted from the available information, and the objectives of Glencore Mangoola mine. The investigation has the following five main components.

- Part (a): Review of available information;
- Part (b): Instrumentation and measurement to quantify the actual dynamic behaviour of the machine (Note: this is required to understand the fatigue loading on the bolts and machine operations contributing to fatigue);
- Part (c): Modelling and simulation using finite element modelling and other analytical methods;
- Part (d): Overall assessment taking into account information from all three above steps;
- Part (e): Development of improvement and preventative strategies.

Accordingly, the following were the key steps of the investigation:

- Step 1: Gathering available information and relevant data from the site related to the failure and review of failure history.
- Step 2: Discussion with site staff and operators and observation of current machine operating conditions on-board the machine to understand the vibration levels on the machine and cab riser.
- Step 3: Preliminary modelling and analysis on the cab riser to determine the instrumentation plan and instrument locations for sensors (strain gauge placement on attachment block, displacement transducers and tri-axial accelerometer) to understand the structural behavior.
- Step 4: Install MTI's Structural Monitoring System (SMS) on excavator EX151 with additional instrumentation to monitor stresses at critical areas of the structure and to understand stresses and movements experienced by the structure and cab riser critical components such as the bolts during operations.
- Step 5: Conduct specific testing to understand operating practices that have a major influence on the excavator and cab riser connection bolts.
- Step 6: Conduct Finite Element (FE) analysis based on measured SMS data. SMS data such as accelerometer and displacement transducer measurements were used in FE modelling to understand the deflection of cabin and stresses experienced by bolts.
- Step 7: Analysis of measured SMS data over a period of 3 months, and conduct fatigue assessments based on measured data and FEA.
- Step 8: Development and recommendation of a comprehensive risk management strategy to minimize risk of failure, including:
  - (i) Frequency of inspections of NDT;
  - (ii) Periodic maintenance;
  - (iii) Suggestions on improvement to bolt connections to improve fatigue life of attachment bolts and/or eliminate similar failures in the future
- Step 9: Development of comprehensive report with recommendations for Mangoola mine and the general mining industry.
- Step 10: On-going monitoring and reporting as required.

## 4 PREVIOUS INVESTIGATIONS AND THEIR FINDINGS

Two previous investigation reports were made available to MTI by Mangoola mine, and they were:

- (i) ICAM investigation undertaken by Mangoola mine; and
- (ii) Bolt failure investigation undertaken by Bureau Veritas.

A brief overview of these two investigations, relevant for the current investigations, are given in this section. These findings and conclusions were given due consideration and were tested during the MTI investigation without accepting them as factual on face value.

The segments extracted from the two investigation reports are given in blue colour font within inverted comas for ease of differentiation.

### 4.1 SUMMARY AND FINDINGS OF ICAM INVESTIGATION

#### 4.1.1 Key Finding of ICAM

ICAM reported the following as a key finding:

“The Maintenance Dept. personnel involved in the decision making process were of the view that interim repair would be adequate to retain and secure the riser and cab. It was the belief that the shift inspections would identify any deterioration of the interim repair in time to repair it before a catastrophic failure occurred.”

Four bolts that were broken could not be effectively replaced. Therefore, the attachment heavily depended on the interim repairs. This interim repair also failed during the final failure and hence that had not been adequate to ensure structural integrity. There is no documentation of the details of the interim repairs to examine its adequacy.

#### 4.1.2 Root Cause

The following two statements of the ICAM report identify the root causes for the failure, as identified by ICAM.

- (i) “Post incident analysis to determine the root cause for the failure of several riser retaining bolts after more than 30,000 hours indicates misalignment between the riser and the chassis mounts as the probable cause. The misalignment, likely caused by an unidentified event or impact, has placed additional stress on the bolts causing them to fatigue and progressively fail over time.”
- (ii) “The root cause of the incident was identified as the failure of the design and monitoring program to detecting the failing state of the interim repair.”
- (iii) It is not clear whether misalignment mentioned here was a result of bolt failures, or whether it was the reason for the bolt failure.

#### 4.1.3 Other Contributing Factors

ICAM report identify other factors listed below as possible contributory factors, but they are not directly relevant for the MTI investigation. However, this information provided an insight to the maintenance background that existed during five month period of the progressive bolt failure.

##### (a) Maintenance Management

“Insufficient formal documentation was in place to control the interim repair design and monitoring given the consequence of failure and length of time the interim repair was relied upon.”

“Liebherr (OEM) had inspected EX151 and were aware of the status of the broken bolts and interim repair measures, however there is no evidence any advice given or obtained from Liebherr in regards to the significance of the broken bolts, adequacy of the repair, or other actions required.”

*(b) Organisational Culture/Maturity of System*

“Maintenance Work Teams may have become desensitised to the requirement to conduct inspections on the interim repair as no deterioration in condition was being reported.”

*(c) Procedures*

“Evidence suggests interim repairs are common place and considered a routine part of maintenance. Despite the existence of Risk Management Procedures there is no process or procedure in the Mangoola Health & Safety Management System that clearly deals with the specific requirements involved in the management of interim repairs in maintenance.”

“Each PM Service Sheet identified a requirement to “Inspect Cab Mounts” or to “Inspect ROPS and Cab security” but did not specifically refer to the cab riser mounts. Evidence exists of the inspection being conducted and signed off with no fault reported on all but two occasions. One of these occasions was the first report of a riser bolt failure suggesting that some Maintainers were inspecting the riser mounts. No FMEA could be found to justify the purpose of these inspections.”

#### **4.1.4 Conclusions of ICAM Investigation**

The main conclusions of the ICAMS investigation were as follows.

*(a) Understanding Root Cause*

“Misalignment found between the riser and the chassis mounts suggest an unidentified event or impact may have occurred which could have overloaded the bolts causing them to progressively fail over time. Recognising and investigating if this was a potential cause may have assisted in reducing the potential for more bolt failures if the cause was able to be rectified or an alternative and more effective interim repair option identified.”

The conclusion that misalignment between riser and chassis mounts led to the failure was investigated.

During the three month period MTI was monitoring the machine with the installed instrumentation system, no singular significant events that could cause misalignment of the bolts was detected. Obviously, the inability to effectively replace the first two bolts that failed in May 2016 had the potential to make the bolt alignments change significantly and also increase the fatigue loading on the remaining four bolts.

*(b) Planned Maintenance Requirements*

“The planned maintenance requirements of the cab riser bolts and their integrity to prevent the riser bolts falling into failure mode requires improvement. The maintenance strategy needs to be reviewed in reference to the cab mounts and cab riser in consultation with the OEM and adopted to the maintenance life cycle of the EX151 excavator.”

See Section 9 for MTI recommendations for future maintenance strategies.

*(c) Risk Assessment*

“A documented Risk Assessment conducted prior to the interim repair may or may not have identified a heightened risk leading to an alternative repair method or a full and proper repair being necessary.”



“Evidence suggests interim repairs are common place and considered a routine part of maintenance. Despite the existence of Risk Management Procedures there is no process or procedure in the Mangoola Health & Safety Management System that clearly deals with the specific requirements involved in the management of interim repairs in maintenance.”

The maintenance strategies suggested in Section 9 of this report should eliminate the need for interim repairs. However, if interim repairs are necessary in the future MTI can provide an assessment on an as needs basis.

*(d) Design criteria and Quality of Inspections of Interim Repair*

“Insufficient formal documentation was in place to control the interim repair design and monitoring given the potential consequence of failure and length of time the interim repair was relied upon.”

“Assumptions were made that the Fitters clearly understood what to look for when inspecting the interim repairs and that the Supervisors would be diligent in recording the inspection results. There is a potential that further failure of the remaining riser bolts and or interim repair had gone undetected for some time progressing to the final catastrophic failure.”

“The instruction to inspect the interim repair each shift was an additional control measure to confirm effectiveness and ability of the interim repair to last until the planned shutdown in November. A heavy reliance was placed on the quality of those inspections which were shown to be inadequate in confirming effectiveness of the interim repair to prevent it progressing to a full failure.”

It is clear that the perception that seems to have existed that the interim repair was effective enough had been a factor for the unexpected catastrophic failure. None of the four bolts (out of the total of six bolts) that had failed by 12<sup>th</sup> August 2016 seem to have been effectively replaced.

This also points to the poor consideration given to maintainability during the design of the attachments. In the current design, the entire riser and the cabin assembly need to be dismantled to remove the broken piece of a bolt in the tapped hole in the chassis. Improvements have been suggested in this report to make at least some of the bolts replaceable without removing the riser.

#### **4.1.5 ICAM Recommendations**

The following were the recommendations of the ICAM investigation.

- (a) “Develop an Interim Repair TARP which will provide a structured process for decision making, risk based approval and monitoring of interim repairs.
- (b) Communicate to key personnel the requirement to maintain accurate and timely records for ongoing monitoring of equipment with Interim Repairs and the requirement to escalate deteriorating conditions.
- (c) Review the Maintenance Strategy around Cab Riser maintenance and update PM documents to be more descriptive in pass / fail limits.
- (d) Share learnings with OEM and obtain any feedback or forward recommendations relation to cab and riser maintenance recommendations for Mangoola and other sites.
- (e) Review Mechanical Engineering Control Plan as required in the triggers for review.”

## 4.2 SUMMARY AND FINDINGS OF BUREAU VERITAS BOLT INVESTIGATION

### 4.2.1 Overview

- (a) The issue date of Bureau Veritas (BV) report [2] is 3<sup>rd</sup> November 2016.
- (b) BV examined only two of the failed bolts – see Figure 4-1. One of them was a vertical bolt (i.e. rear outer bolt D in Figure 2-1) and the other was a horizontal bolt (i.e. rear horizontal bolt E in Figure 2-1). These are the last two bolts in place just prior to the final failure.
- (c) The bolts were 265 mm long and the ends were broken when BV received them. The breakage had occurred in the threaded area.
- (d) According to the specifications, the total length of the bolt is 300 mm (i.e. from the underside of the head) and therefore, these two bolts have broken leaving a ~ 35 mm length inside the threaded chassis attachment point.
- (e) They also examined the Riser and documented the fatigue cracks and other details evident in the riser.
- (f) The parts of the bolts that were stuck in the chassis within the threaded hole were also examined, and photographs were included in the report.
- (g) Hardness and the micrography of the bolt material were examined and confirmed that the material complied with the specified bolt class of Grade 10.9.
- (h) The report concluded that the failure was attributable to fatigue.
- (i) In addition to the stated discussions and conclusions in the report, the photographs given in the report provide many other important information regarding the failure.



Figure 4-1: Two Bolts Examined by BV

### 4.2.2 Information Extracted from Report

Several important information extracted from the report are summarised in this section.

#### *Failed Bolt Segments Left in Chassis Mounts*

Figure 4-2 shows the photographs of the failed bolt segments still left inside the chassis mounts – the bolts are numbered as per as per notation given in Figure 2-1. The following observations can be made from these photos.

- (i) Photos for bolt A mount are not included in BV report.
- (ii) All the bolts have broken at the interface of the riser and the chassis mounts. These areas of the bolts have threads, and therefore threads would have acted as stress raisers.

- (iii) The last two bolts to fail were F and D, and the fresh failure surface seen is consistent with that conclusion.
- (iv) Bolt F show fatigue failure features but bolt D appears to be more of an over load failure. It is likely that the very last bolt holding the riser in position was bolt D.
- (v) One very significant conclusion that can be made from these photos is that the attachment arrangement of the riser to the chassis did not facilitate replacement of the previously failed four bolts (i.e. bolts A, E, C and B) unless the whole riser and the cabin was taken off to remove the bolt segments left behind inside the chassis mounts. The corrosion and oil on mounts particularly on B and C clearly show that the two bolts that were broken in August 2016 could not be replaced until the final failure happened in October 2016. If the failed bolts could be replaced, this failure could have been prevented.

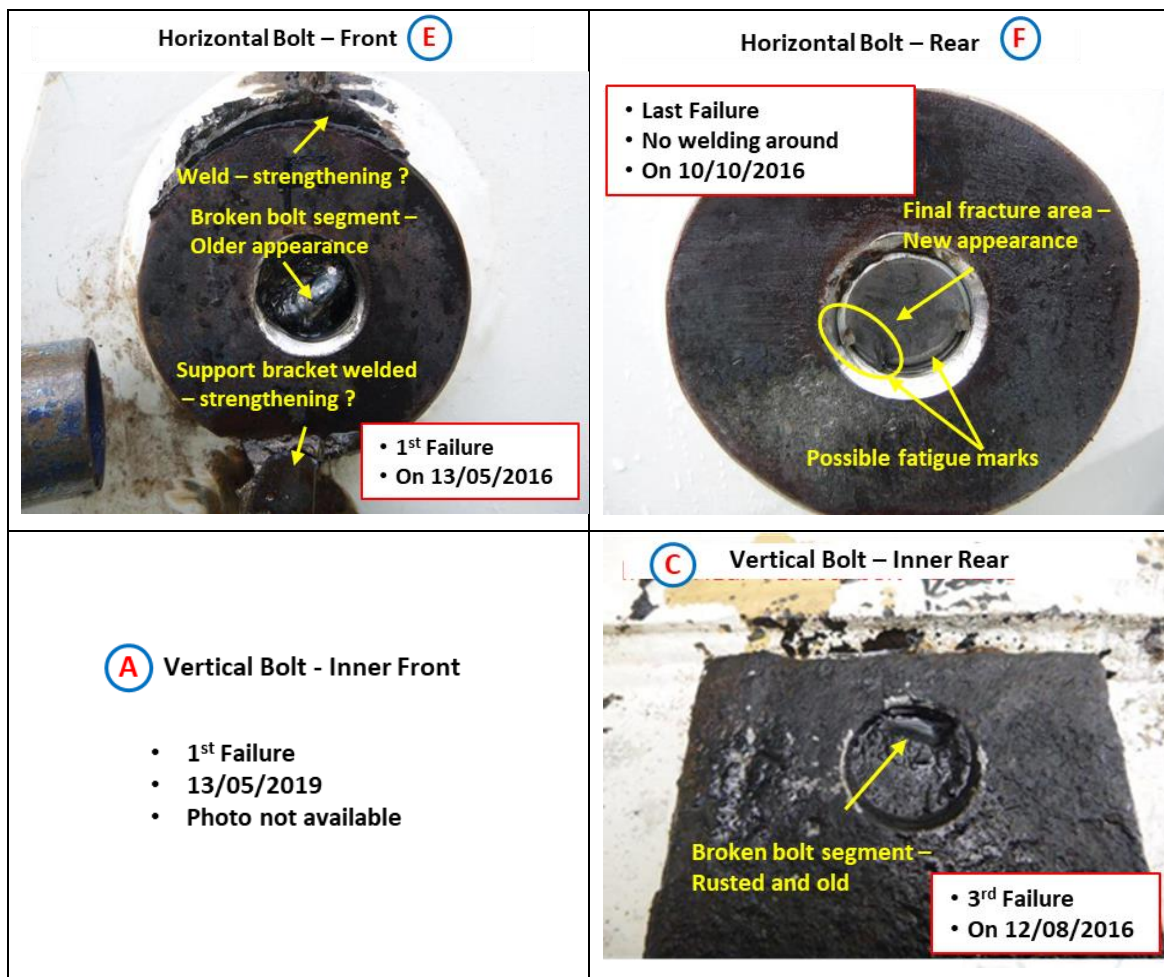



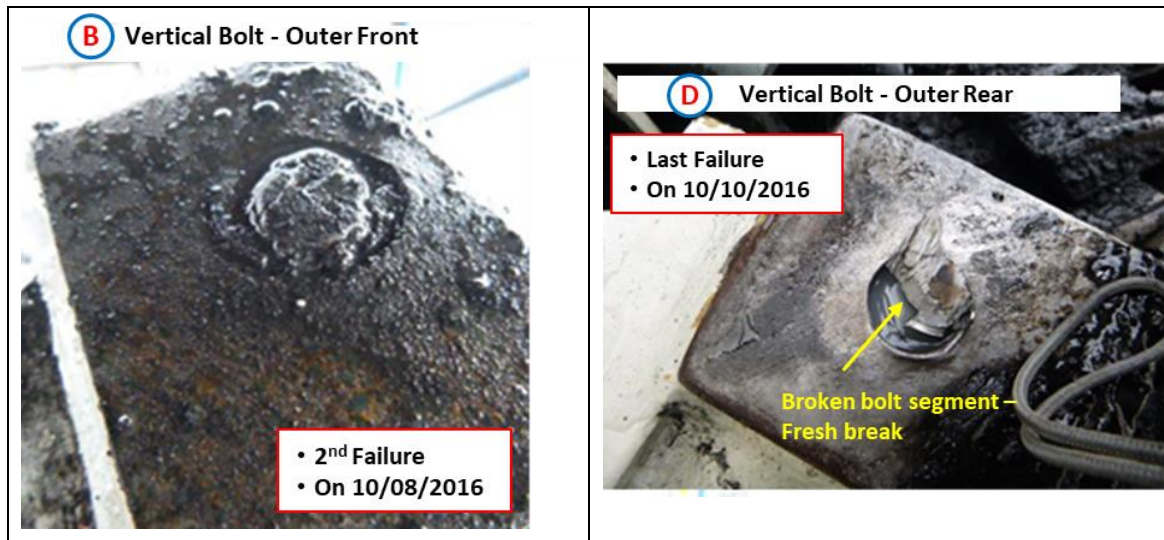

Figure 4-2: Bolt Segments Left in Chassis Mounts

- (vi) Therefore, changing the attachment arrangement to facilitate easy replacement of any broken bolts should be considered.
- (vii) At the mount of front horizontal bolt E, there are some remnants of welds around the circular mount. Further, there is an additional bracket welded below the mount as shown in Figure 4-3. These appeared to be attempts by the maintenance staff to temporarily strengthen the riser attachment to the chassis after the first two bolts were broken in May 2016. Considering the axial and shear capacities of a 30 mm diameter Grade 10.9 bolt, these welds and the bracket are grossly inadequate to replace the attachment strength of the bolt.

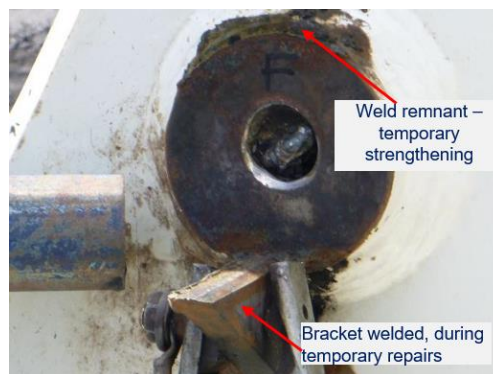

Figure 4-3: Temporary Repairs at Front Horizontal Bolt E

***Wear Marks on Internal Bore Surface of Riser Attachment Blocks***

BV report shows very clear deep indentation marks on the inner bore of the riser attachment through which the riser is attached to the chassis. The following can be observed and deduced from the information.

- (i) The diameter of the horizontal bolt bore is 35 mm while the diameter of the bolt is 30 mm. Therefore, the bore is oversize to the bolt by 5 mm.
- (ii) The yield stress of the Grade 10.9 bolt material is 1000 MPa while the material of the riser attachment could be around 300 MPa. Therefore, if these two materials are

- pressed against each other, the bore will get indented by the bolt threads, with relatively less deformation and wear on the bolts.
- (iii) The photos in Figure 4-4 show quite deep indentation marks of the threads right around the bore. For this to happen the riser must have been moving approximately 2-3 mm and impacting or rubbing on the bolts.
  - (iv) This movement essentially requires some slip between interface between the bottom of the 100x100 mm riser attachment block and chassis mount, i.e. Interface (a) in Figure 4-5. The components, i.e. 100x100 mm riser block, washer and bolt head, may remain locked to each other due to friction. In that case the bolt will be subjected “S” shape bending inducing significantly high stresses at Interface (a), in addition to the axial stress.
  - (v) On the other hand, if the bolt head can also freely slip, e.g. if pretension of the bolt is completely lost, the slip at both interfaces will be very similar and therefore the bolt will not see too much bending. However, if the riser attachment block come and contact the bolt, it will exert a shear force in the bolt. This shear force can also become an impact force depending on the velocity of the contact.
  - (vi) Bolt F is one of the last two bolts failed. Therefore, it can be argued that these thread embossments in the bore of Bolt F may have occurred due to the failure of other bolts previously and the weakening of the connection. However, the bore of Bolt E which is one of the two bolts which failed first also has similar marks. Therefore, it can be concluded that the movement of the riser relative to chassis had been there all along. This is clearly a weakness in the connection design.
  - (vii) The effects of the movement and slip described above will be investigated quantitatively in Section 5.

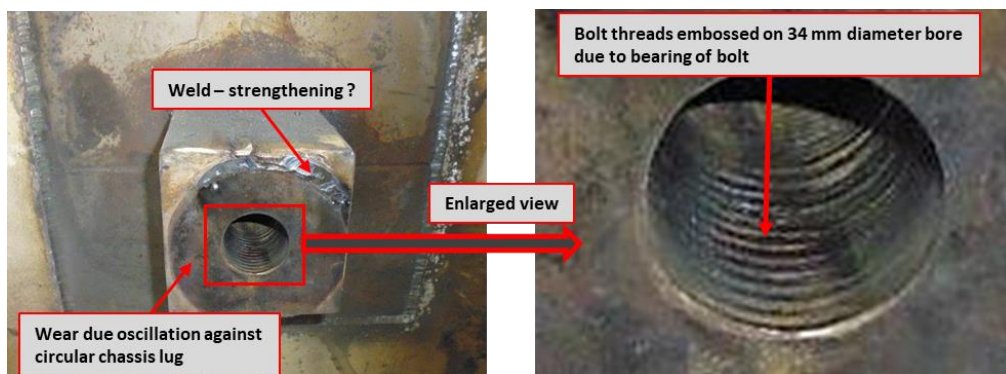

Back of Riser at Front Horizontal Bolt **E**

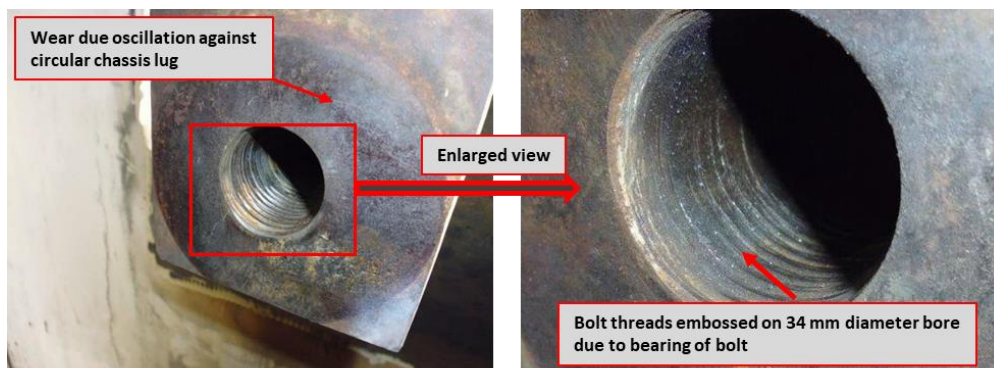

Back of Riser at Rear Horizontal Bolt **F**

**Figure 4-4: Thread Indentation Marks inside Bolt Attachment Bores**

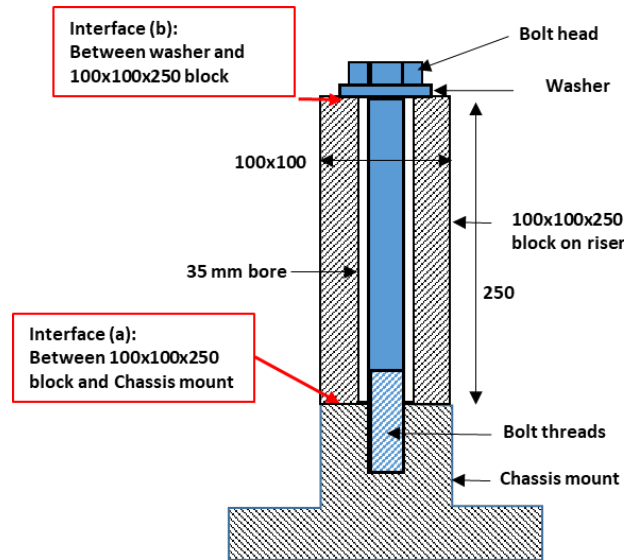

Figure 4-5: Possible Slip Interfaces at Bolted Attachments

### Fracture and Wear Characteristics of Bolts

The fracture surfaces of the two bolts investigated by BV are shown in Figure 4-6 and Figure 4-7. The following observations can be made from the failure features.

- (i) The threads of Bolt D had badly worn out just above the failure point. This is due to the movement of the riser relative to the chassis.
- (ii) Bolt E has a much large fatigue crack propagation area whereas Bolt F has a relatively larger brittle fracture area in the failure cross-section. Therefore, it is very likely that the last bolt to fail was Bolt D. In the final hours of operations prior to final failure, the Bolt F would have failed in fatigue, and soon after that Bolt D would have fractured mainly due to overload.
- (iii) Failure cross section of Bolt F shows some mechanical damage due to contact with the attachment block of the riser. Two fatigue cracks appeared to have initiated from this mechanical damage area. Later on these two cracks seem to have merged into one crack. This crack grew until it covered almost the entire bolt cross section.

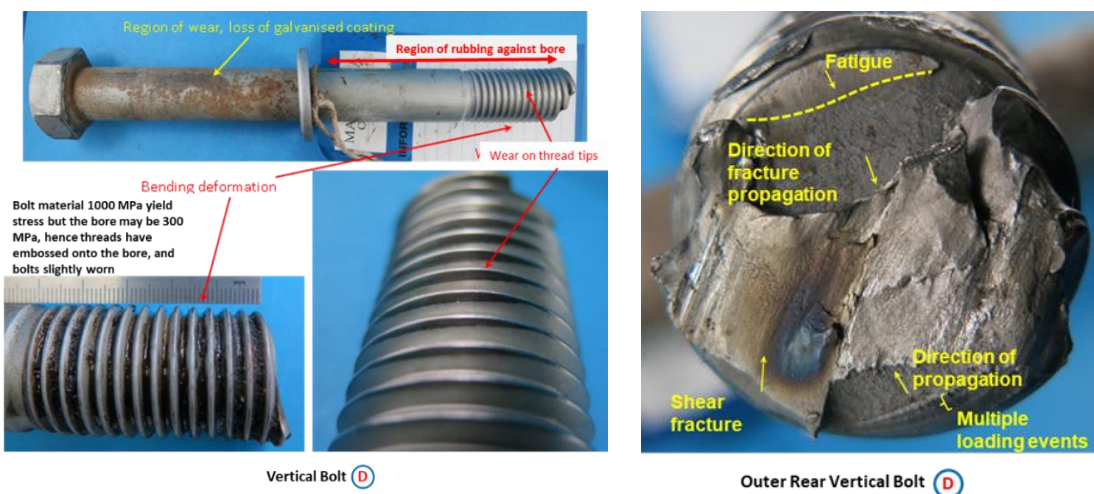

Figure 4-6: Thread Wear on Rear Outer Bolt D





Figure 4-7: Fracture Surface of Rear Horizontal Bolt F

***Fatigue in Riser Structure***

There had been some fatigue cracks in the riser body as well (see Figure 4-8), but these cracks have had no influence on the riser detachment. However, these cracks indicate that the structure has been experiencing vibrations.

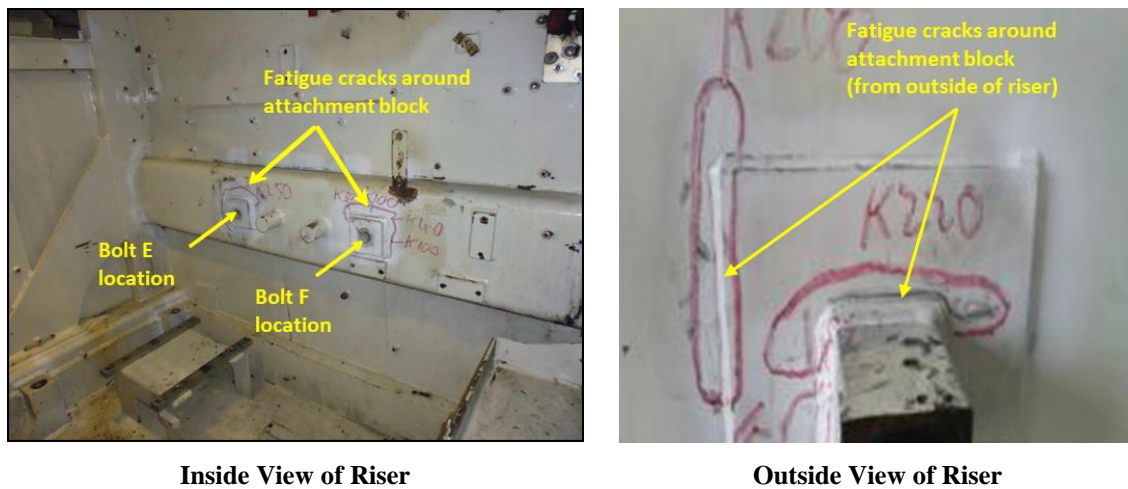

Figure 4-8: Cracks in Riser Body

## 5 INSTRUMENTATION AND MEASUREMENTS

### 5.1 SMS INSTRUMENTATION

#### 5.1.1 Instrumentation of the Excavator Boom, Stick and Bucket

The MTI Structural Monitoring System (SMS) consists of 10 strain gauges installed at critical areas of the boom and stick and three inclinometers installed on the boom, stick and bucket and is used to determine the location of the bucket and to assess the structural performance of the machine. The boom, stick and bucket strut forces (calculated from extend and retract pressures) are also measured by tapping into the hydraulics system.

The system provides real-time feedback to operators on the excavator performance with alarms set at pre-set threshold limits for strength and fatigue damage (see Figure 5-1). The system can determine the operator practices being conducted on the machine at any given time, with the feedback also displayed on the SMS Dashboard in real-time at various remote locations of the mine.

Two SMS data loggers were installed for the SMS and other for the instrumentation on the cabin riser. The locations of the instrumented bolts and strain gauges installed on the excavator and riser are shown in Section 11.1 in the Appendix.

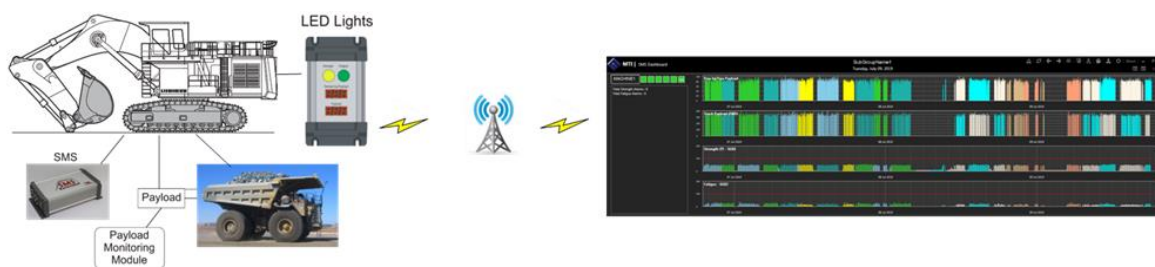

**Figure 5-1: SMS provides real time feedback to operators and site management through the SMS Dashboard**

#### 5.1.2 Instrumentation of the Cabin Riser

In addition to the SMS system, instrumentation of the riser includes the following:

- All six riser attachment bolts were instrumented to monitor the axial loads of the bolts including their dynamic component. A new set of bolts were instrumented and calibrated for this purpose. The bolts in the machine were replaced with these instrumented bolts at site, one bolt at a time.
- Three displacement transducers, in three orthogonal directions, were installed to measure any movement of the riser with respect to the chassis
- A tri-axial accelerometer mounted on the chassis measures the motion of the machine in all three directions
- There had been some repeated fatigue cracking on the steel attachment blocks adjacent to where the two horizontal bolts are located. Two strain gauges placed in the vertical and horizontal directions measure the stresses at these locations. The data from these strain gauges were used to assess the fatigue strength of the welds involved.

Two of the instrumented bolts were replaced on the 28<sup>th</sup> March 2019; the front vertical bolt located on the outer edge of the cabin riser and the horizontal bolt located towards the rear of the cabin. The strain gauges in those bolts appeared to have damaged during the initial installation of the SMS system on 4<sup>th</sup> March 2019.

The SMS system had to be recalibrated during the installation process and as a result, the recorded axial stresses in the functioning bolts were zeroed. The pretension of each bolt measured during the initial SMS system installation were added to the stresses recorded by the SMS system to derive the total actual stress in the bolt.

SMS data collected over a period of three months from 28<sup>th</sup> March to 20<sup>th</sup> June 2019 was used to analyse the fatigue life usage of the bolts and to relate the operating practises of the machine to the stresses experienced by the bolts.

## 5.2 TYPICAL DATA AND MAIN FEATURES

### 5.2.1 Pretensions in Bolts

The six bolts used for the attachment of the riser to the chassis were pretensioned during installation. The recommended pretension was provided by the OEM (specified torque of 1920 Nm). As the torque coefficient used was not specified, a coefficient value of 0.2 was assumed. Hence, this torque converted to a tension in the bolt is 320 kN (570 MPa). Given that the bolts are Grade 10.9, this pretension is equivalent to 57% of proof stress.

Generally, connection bolts can be pretensioned up to approximately 90% of proof load. However, for the EX151 excavator at Mangoola Mine, the OEM has recommended a significantly lower pretension to be used compared to general practice.

The strain gauges in bolts were zeroed before installation, so that pretensions in each bolt could be measured by the instrumented strain gauges measuring axial loads in the shank of the bolt. The pretensions measured after installation for all bolts, including replaced bolts are as shown in Table 5-1 below.

**Table 5-1: Pretension measured after installation of all bolts on 28<sup>th</sup> March 2019**

Bolt Notation	Instrumented Bolt	Pretension Stress (MPa)	Pretension Stress (% Proof Stress)
B	SG01 – Vertical Bolt Front (Outer)	755	75.5
A	SG02 – Vertical Bolt Front (Inner)	180	18
E	SG03 – Horizontal Bolt Front	590	59
F	SG04 – Horizontal Bolt Rear	980	98
C	SG05 – Vertical Bolt Rear (Inner)	125	12.5
D	SG06 – Vertical Bolt Rear (Outer)	275	27.5

As can be observed from the pretension measurements in Table 5-1, the pretension values for the bolts vary significantly (ranging from 125 MPa to 980 MPa), and only 3 bolts (SG01, SG03 and SG04) had achieved the intended 57% of proof stress. For bolts subjected to oscillating axial loads, the pretension is crucial to minimise fatigue loading on bolts. Adequate pretension applied to a bolt has the ability to shield the bolt from fatigue loading; thereby greatly increasing the fatigue life. This is discussed further in detail in Section 6.1

It should be noted that the OEM did not provide to Mangoola Mine a recommended sequence for installation for the bolts to ensure that the required pretension of the bolts were achieved. In addition to that, the pretension in some bolts could have been reduced since no re-tightening sequence was provided.

### 5.2.2 SMS Data

The SMS data trends for the period between 28<sup>th</sup> March and 20<sup>th</sup> June 2019 are illustrated in Figure 5-2. Highlighted regions show high fatigue life usage in both the rear vertical bolts SG05 and SG06 and in gauge SG12 located adjacent to horizontal bolt SG03 on the attachment block. MTI has obtained Fleet Management System (FMS) data from Mangoola site to further investigate periods of high fatigue life usage and the sudden increase in the cumulative damage in the rear vertical bolt. It can be observed that the regions with high fatigue life usage and the sudden increase in cumulative damage of the bolts coincide with periods where mostly coal was dug. Based on the measured data collected throughout the investigation period, the fatigue life when digging coal is reduced by 74% compared to when digging other materials. This is potentially due to the coal not being ripped to aid the dig process. Consequently, operators are inclined to exert more force to dig ground; increasing the fatigue life usage of the machine. The sudden increases in cumulative damage of the gauges in the boom structure also coincide well with periods when coal is dug. The SMS has been designed to monitor dig conditions and machine performance and provide real-time feedback to the operator.

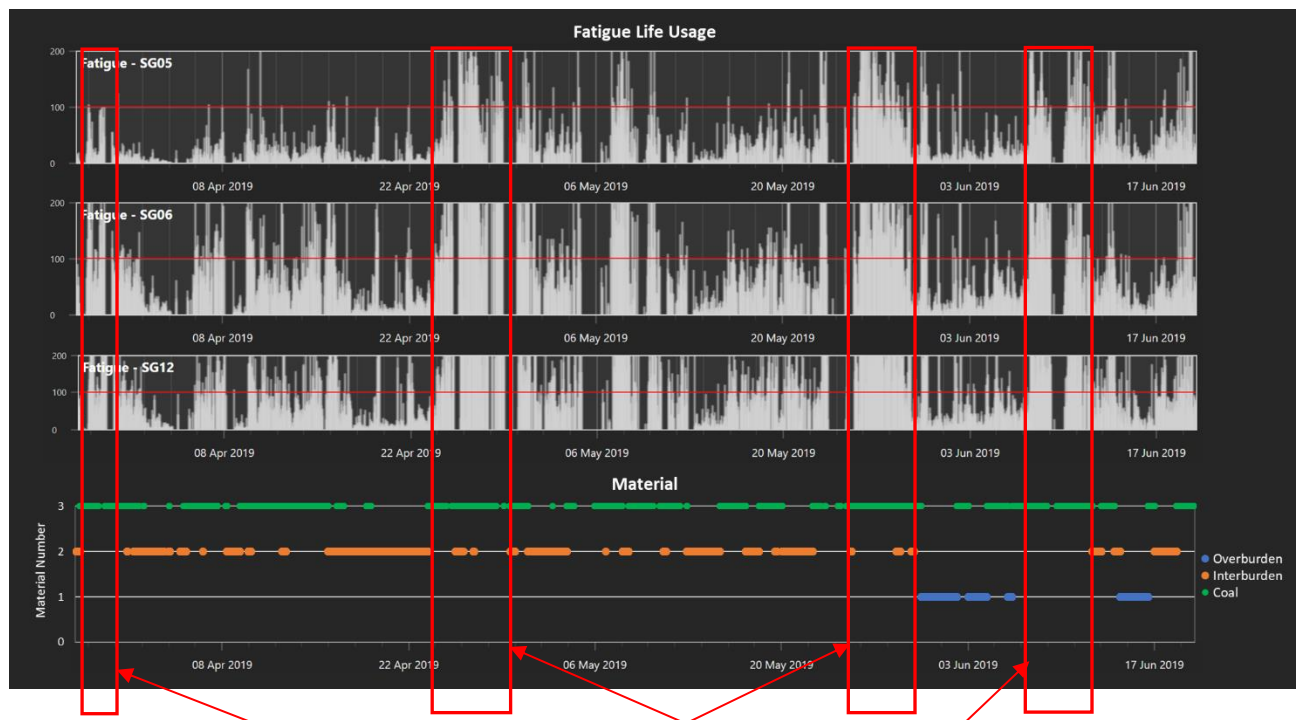

Highlighted regions show high fatigue life usage in both the rear vertical bolts SG05 and SG06 and in gauge SG12 located adjacent to horizontal bolt SG03 on the attachment block which coincide with periods when coal was dug

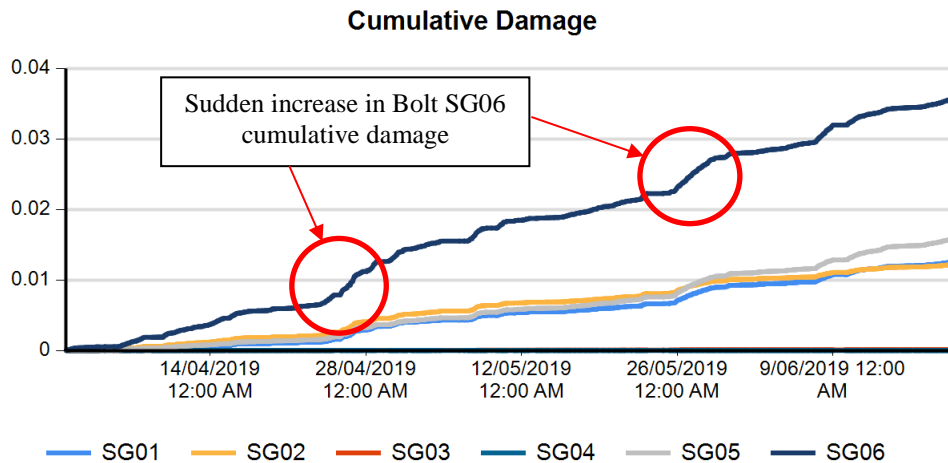

**Figure 5-2: Fatigue life usage and cumulative damage of SMS instrumented bolts for the period 28th March to 20th June 2019.**

A sample of data from 24<sup>th</sup> April 2019 10:00PM is shown in Figure 11-1 and the corresponding measured data from the instrumented bolts, tri-axial accelerometer and displacement transducers are shown in Figure 11-2. The highlighted region in the data sample shows an increase in the stresses across all gauges in structure and in all the instrumented bolts compared to periods of regular digging in the other sections of the data sample. The operator was digging coal for the entire period. A detailed observation of a specific instance during this period is shown in Figure 11-3 and Figure 11-4 available in Section 11.2 of the Appendix.

The following were observed:

- (i) Downward boom force was applied at the start of dig to break ground. The operator had also used the edge of the bucket to scrape/loosen the ground (gardening) to ease the digging process, causing large side loads to be experienced by the machine.
- (ii) Large stress reversals throughout the boom structure were observed as a result of these practices.
- (iii) The sudden impact with side load also caused significantly large vibrations and stress spikes especially in the vertical bolts which may have resulted in bending of the bolts.
- (iv) The stresses in the vertical gauge SG11 and horizontal gauge SG12 (located adjacent to the front horizontal bolt SG03) also show an increase in the peak stresses during this period.
- (v) The magnitude of the displacement of the cabin riser in the horizontal and vertical directions are amplified when a downward force is applied with side load at the start of dig which would have resulted in bending of the bolts.
- (vi) The periods in the data sample where the machine was digging regularly show a significantly lower stress range and a minimal number of high stress reversals. A combination of good operator practices and ground preparation will increase the life of the machine and avoid sudden propagation of cracks in the structure and the bolts connecting the cabin riser to the machine chassis.



On the 21<sup>st</sup> May, MTI conducted a site visit to Mangoola Mine to perform specific testing on the machine. Over the period of one hour, a few of the operator practices that would be most damaging to the machine were carried out during normal dig/loading operations. Two detailed data samples extracted during the specific testing are shown in Figure 11-5 to Figure 11-8 in Section 11.2 of the Appendix.

Video footage synched with the measured data for both data samples have been provided with this report to better demonstrate how the stresses relate to operator practices and the effect of poor operator practice on the fatigue life of the machine.

The sample of data from 21<sup>st</sup> May 2019 9:20AM is shown in Figure 11-5 and the corresponding measured data from the instrumented bolts, tri-axial accelerometer and displacement transducers are shown in Figure 11-6.

The following were observed:

- (i) Downward boom force was applied at the start of dig with the boom, stick and bucket fully extended, causing large stress spikes throughout the boom structure especially in the boom mid-section (SG03 and SG04) when the bucket impacted the ground suddenly.
- (ii) The sudden impact with slight side load also caused significantly large vibrations and stress reversals in all the attachment bolts and also recorded significant horizontal displacement measurements.
- (iii) The stresses in the vertical gauge SG11 and horizontal gauge SG12 (located adjacent to the front horizontal bolt SG03) also show large stress reversals during this incident.

A sample of data from 21<sup>st</sup> May 2019 9:22AM is shown in Figure 11-7 and the corresponding measured data from the instrumented bolts, tri-axial accelerometer and displacement transducers are shown in Figure 11-8.

The following were observed:

- (i) Similar to above, a downward boom force was applied with side load at the start of dig with the boom, stick and bucket fully extended, causing large stress spikes throughout the boom structure especially in the boom mid-section (SG03 and SG04).
- (ii) The stress spikes are in opposite directions, indicating bending of the boom structure when the bucket impacted the ground suddenly under significant side load.
- (iii) Significant displacements between the cab riser and chassis were also recorded which would cause bending in the bolts.
- (iv) The stresses in the vertical gauge SG11 and horizontal gauge SG12 (located adjacent to the front horizontal bolt SG03) also show large stress reversals during this incident, especially in SG12.



## 6 MODELLING AND ANALYSIS

The Section 6.1 below describes the theoretical analysis undertaken on one of the connections using a theoretical model found in literature. This analysis was undertaken mainly to demonstrate the importance of initial pretension settings and the bolt connection maintenance over time.

The finite element modelling and analysis undertaken and its results are discussed in Section 6.2.

### 6.1 THEORETICAL MODELLING OF BOLTED CONNECTIONS

The pretension stress recommended by the OEM is 0.57% of the proof stress of the bolt. Since tightening of one bolt can affect the tension in a previously tightened bolt(s), it is preferable to have a tensioning sequence specified. The OEM has not provided a tightening sequence, hence a tightening or re-tightening sequence has not been implemented so far.

Pretensions can be very effective in transferring riser loads to the chassis through friction-grip behaviour, particularly the loads perpendicular to the bolt axes, and could also help reduce the relative movement between the riser and the chassis.

The main advantage of pretension in a properly designed bolted connection is that a great proportion of the fatigue loading component in the axial direction of the bolt will be absorbed by the changes in the interface compression, reducing the exposure of the bolt to fatigue loading in the axial direction of the bolt. It can also reduce bending related fatigue at a connection similar to what is used in the riser by controlling the interface slip in the transverse direction to the bolt axis.

The above aspects are investigated in this section using a theoretical model found in literature.

#### 6.1.1 Brief Literature Review

A simplified model to investigate the behaviour of a typical connection under different pretension loads was found in [3]. One of the horizontal bolts was analysed using the model given in [3]. The results of this analysis are discussed in Section 6.1.2 and Section 6.1.3.

Given that maintaining appropriate pretension in bolts is important for the performance of the bolted connections and also the fatigue life of the bolts, it is important to understand the possible phenomenon that can lead to loss of pretension. One such phenomenon is “vibration loosening of bolts” which is discussed in [4].

Given the geometry of the system, i.e. the way the cabin riser is attached to the chassis, and the dynamic loading due to operations, vibration loosening of bolts is a phenomenon that is possible in this structural system. If bolts get loosen due to any reason, the fatigue damage accumulation rate is likely to be increased.

#### 6.1.2 Analysis of Connection of Bolt D using [3]

One of the horizontal bolts was analysed using the model described in [3].

Two cases were analysed:

Case 1: 0.8 x proof stress = 0.8 x 900 = 720 MPa

Case 1: Bolt pretension = 0.8 x proof stress x cross section area = **508.9 kN**

Case 2: 0.6 x proof stress = 0.6 x 900 = 540 MPa

Case 2: Bolt pretension = 0.6 x proof stress x cross section area = **381.7 kN**

Bolt grade	= Grade 10.9
Bolt size	= 30 mm diameter
Cross section area	= 706.8 mm <sup>2</sup>
Tensile strength of bolt material	= 1000 MPa
Proof stress of bolt material	= 1000 x 0.9 = 900 MPa

The parameters of the connection needed for the model were calculated from the geometry shown in Figure 6-1. The dimensions of the components were taken from the solid model of the chassis and the riser provided by OEM. The stiffness of the components at the connection were taken into account.

The loads applied in the form of inertia loads on the cabin in the direction shown in Figure 6-1 were considered for the analysis. They are the loads applied in the axial directions of the bolt. Although there are inertia loads in the forward and aft direction and also in the vertical direction, these inertia loads do not apply a force in the axial direction of the bolt (they cause bending in the bolt but not axial forces).

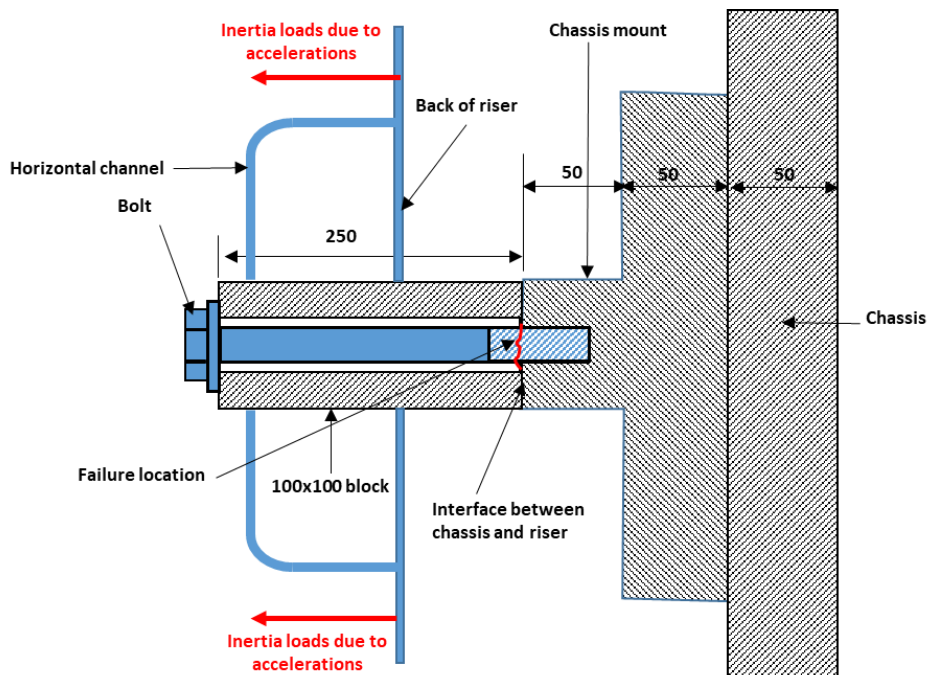

**Figure 6-1: Geometry of Horizontal Bolt Connection used for Analysis**

The results of the analysis for the two cases are summarised in Figure 6-2 and Figure 6-3 below.

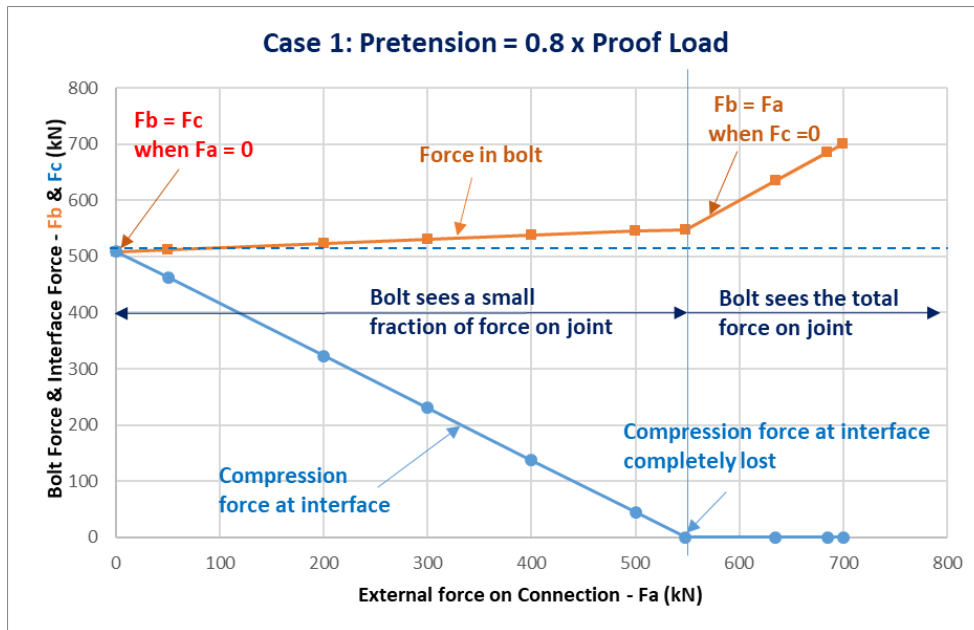

Figure 6-2: Connection Analysis – Case 1 (0.8 Proof Load)

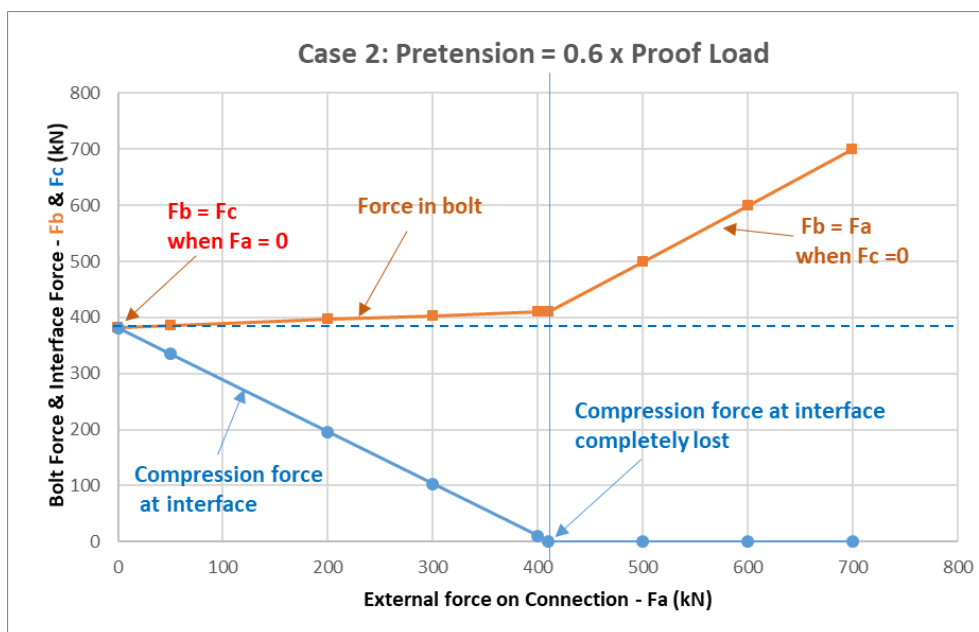

Figure 6-3: Connection Analysis – Case 2 (0.6 Proof Load)

In these two figures:

- The vertical axis is the magnitude of the bolt force and the interface force.
- Horizontal axis is the external force applied on the connection due to inertia forces externally or the interface force.
- The red line graph shows the variation of the bolt force as the external force is increased.
- The blue line graph shows the force at the interface between chassis and the riser as the external force is increased.

The following observations can be made from the graphs:

- The bolt force graph has two portions with different slopes. In the first part of the graph, as the external force increased, the bolt force increases slowly but most of the external load is absorbed by the reduction in the interface compression. Therefore, the bolt is not subjected to high stress reversals due to the dynamic external loads.
- The proportion of the load increment absorbed by the bolt changes with the stiffness of the structure around the bolt. Higher the stiffness of the connection, lower the component absorbed by the bolt. Generally, for stiff connections it is often assumed that the bolts are not exposed to fatigue due to the dynamic applied load. In this case, the entire external dynamic load is assumed to have been absorbed by the varying interface compression force.
- At some point the compression force at the interface is completely overcome by the applied load. This is technically called “failure of the connection”. Thereafter, the bolt has to absorb any further increases in applied load completely.
- Obviously, if the bolt operates in the shallower slope, then it will see a very low fatigue loading, but if it operates in the steeper part as well, then the bolt will see high fatigue loading.
- Comparing the two figures, it can be seen that when the pretension is low, the shallower portion of the bolt force curve become shorter and shorter. Therefore, the likelihood of bolt experiencing high fatigue loading becomes higher.
- A well designed connection of this type should:
  - Keep the pretension as high as possible, say 0.8-0.9 of proof stress. It was noticed that the initial pretension setting used at the site were too low (OEM has recommended 0.57% of proof stress) compared to the above-mentioned values. The measured pretension of the installed instrumented bolts were 0.12 to 0.98 of proof load.
  - Maintain the pretension over time.
  - Make the bolts mainly work in direct tension, unless they are designed particularly for variable bending and shear loads (generally in most well designed connections, bolts do not see shear due to friction grip effect).

If the connection is designed that way, despite the variable loads, the bolts will experience very little fatigue damage.

### **6.1.3 Conclusions from Analysis**

The above analysis has shown the importance of pretension in the riser to chassis connections. It is clear that insufficient attention has been given to pretension of the bolts and the general behaviour of the connections under combination of the loads applied at the connections. The OEM has not provided bolt tightening procedure to achieve the recommended pretension of the bolts.

The evidence extracted from the BV report in [2] clearly indicate that the bolts have been subjected to bending and shear in addition to the dynamic axial loads.

The current design of the connection has of room for significant improvements.

## 6.2 FINITE ELEMENT MODELLING

### 6.2.1 Bolt stress concentration factors

Failure of all six bolts had occurred in the threaded area at the interface between the riser attachment block and chassis mount. The strain gauge measurements of the bolts give the axial tension experienced by the shank of the bolt. However, the highest stresses experienced by the bolts are in the threads.

To take into consideration the increased stresses in the bolt thread notch, a finite element (FE) model of the M30 bolt identical to the attachment bolts of the riser was developed to determine the stress concentration factors due to both axial loading and bending of the bolt respectively.

A fixed load was applied in the direction of the length of the bolt, while the bottom surface of the bolt is held as a boundary condition. The ratio between the stress in the thread notch and the stress in the shank of the bolt is taken as the axial stress concentration factor. The stress concentration factor due to axial stress was applied to the stress measurements recorded by the strain gauge in each of the six instrumented bolts.

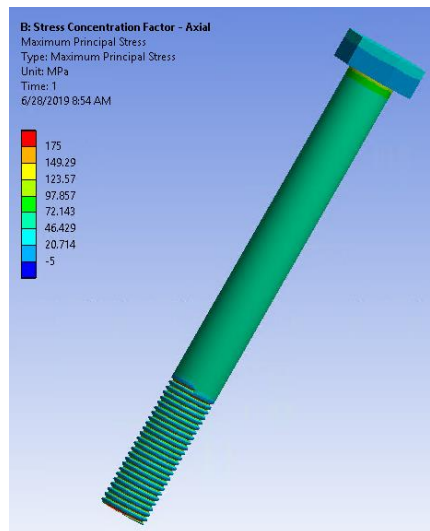
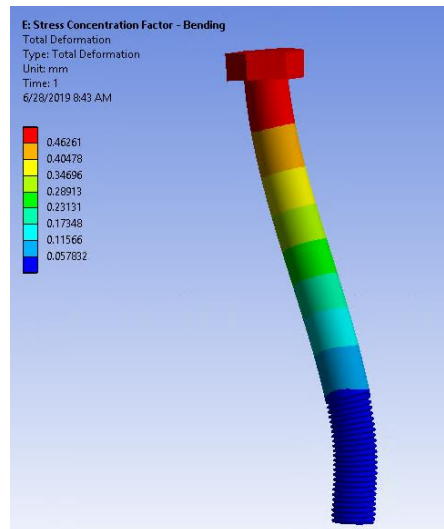

**Figure 6-4: Axial load applied to M30x300 bolt to determine axial stress concentration factor**

The recorded displacements measured by the transducers installed represent the relative movement between the chassis and the riser. Since bending stress in the bolts cannot be directly measured, the transducers were used to calculate the additional component of bending stresses induced on the bolts. The bending stress calculations are based on the formula for a solid circular cross-section and do not consider the notched geometry of the threaded section in the bolt, and the assumption is made that the 100x100 mm riser block, washer and bolt head remain bonded to each other due to friction (i.e. with no relative movement) which would result in an “S” shape bending of the bolt shown in Figure 6-5 below.

If the movement at the interface is reversing in direction, then the bolt will bend back and forth into the “S” shape causing fatigue. The maximum stresses in the bolt will then be induced at the cross section just above the attachment block – this is very consistent with the actual failure locations of the bolts.





**Figure 6-5: “S” Shaped bending in the bolt occurs when there is no loss in pretension stress**

To determine the stress concentration factor due to bending, a calculated deflection, based on SMS system measurements of the displacement transducers, is applied to the bolt head while the length of the shank between the bottom of the bolt and the point at which the interface between the chassis mount and attachment block is located is constrained. The ratio of the stress in the thread notch to the calculated bending stress is taken as the stress concentration due to the bending moment. The stress concentration factor due to bending of the bolts were applied to the calculated bending stress in each bolt.

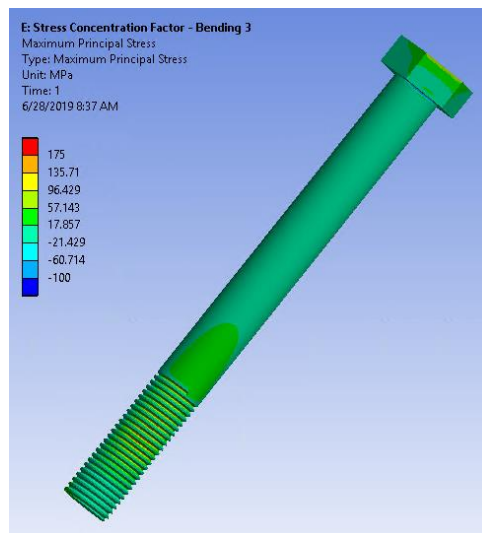

**Figure 6-6: Displacement applied to M30x300 bolt head to determine bending stress concentration factor**

The fatigue life calculations of the attachment bolts were completed with the factored stresses for both the axial (2.6) and bending (1.9) stress components induced on the bolts.

### 6.2.2 Cabin Riser

In order to assess the fatigue life usage of the attachment bolts and verify the measurements of the SMS System, a finite element (FE) model was created using the geometry model of

part of the chassis (where the riser is attached) obtained from the OEM through Mangoola mine. For the purpose of this investigation, results from this FE model were used to determine if the measured displacements were due to the deflection experienced by the riser wall or if the riser was sliding which would cause bending in the horizontal and vertical bolts during digging.

The measurements recorded by the displacement transducers show vibrations and significant spikes occurring occasionally. Further observations show that these fluctuations/sudden increases coincide with peaks in the accelerations measured and also with stress spikes in the instrumented bolts. The observations above suggest that the movement of the structure may induce a significant bending stress component on the attachment bolts.

SMS data used as input to the FE model was selected from a period when the machine was operating under more severe digging conditions; i.e. when the bucket has suddenly impacted the ground with side load at the start of dig. To apply boundary conditions to the model, the surface of the slew on the bottom of the chassis was held as a fixed support, and the interface between the attachment blocks and the chassis mount was bonded to represent no slip and no loss in pretension for all bolts (i.e. the bolted joint is 100% effective). Point masses were already included in the model provided by the OEM to represent the non-structural components of the machine such as the safety ladder, electrical box, cab, left and rear catwalks and guard railing.

An acceleration measured by the SMS in the transverse (horizontal direction) was applied to the entire structure. The resulting deformation in the horizontal direction only is shown in Figure 6-7 below. The FE model was also run considering no additional applied loads other than self-weight. The FE model analysis was repeated by applying the measured acceleration in the longitudinal and vertical directions to separate FE models so that the resulting displacement in each direction could be analysed separately.

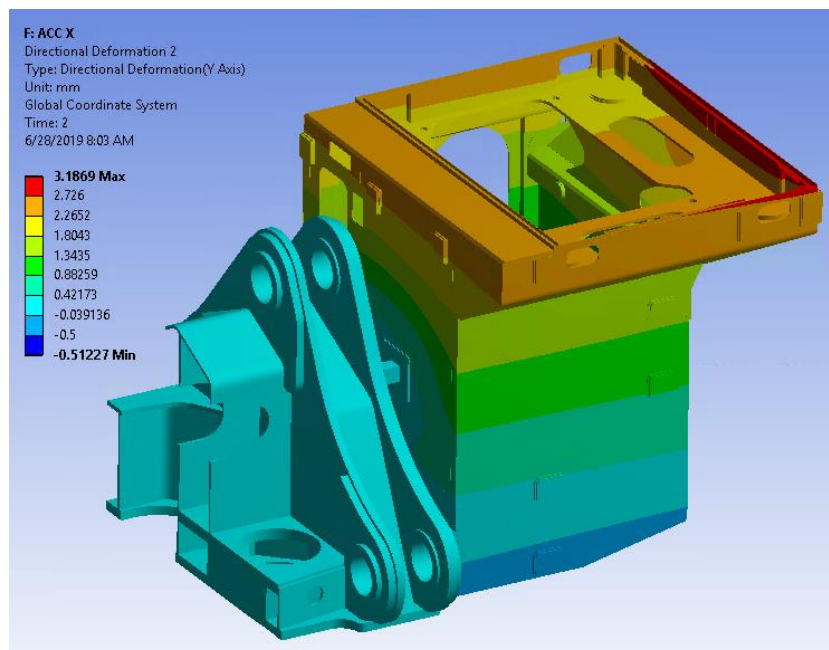
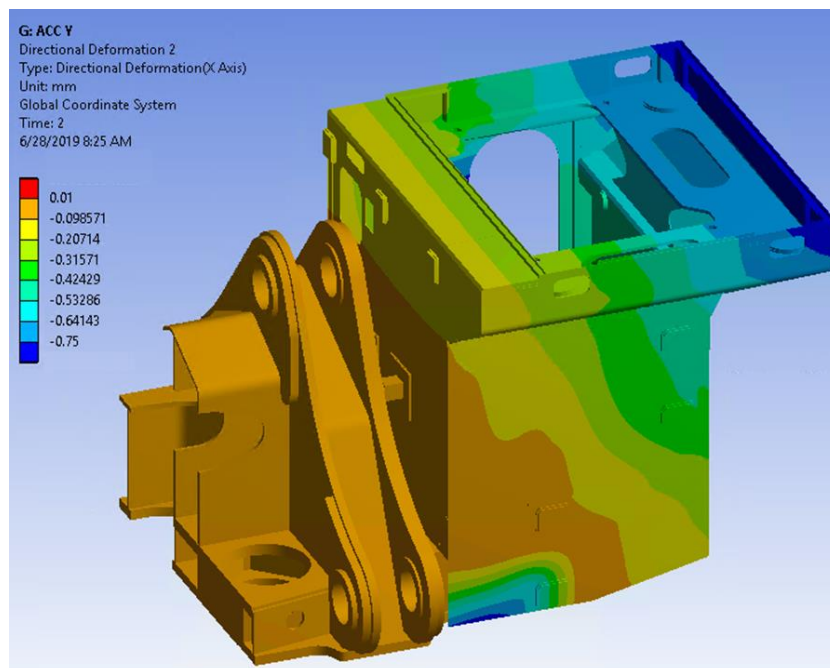

Figure 6-7: Deformation of the cabin riser in the transverse direction

Results from the FE model when an acceleration is applied in the transverse (horizontal) direction shown in the figure above show that there is some deflection in the cabin riser wall adjacent to the chassis. The deformation in the FE model (at the location where the displacement transducer was installed) was compared against the measured value recorded by the displacement transducer. It was observed that under the same loads, the ratio of deformation obtained from the FE model to measured data in the horizontal direction is approximately 34%. Meaning that 34% of the measured displacements are due to the deflection of the riser body and the remaining 66% is due to the riser sliding with respect to the chassis.

The operating practices of the machine which cause a transverse acceleration to the structure has resulted in a deflection of the riser wall adjacent to the chassis, and has additionally also forced bending of the vertical bolts. It should be noted that although it appears that bending is present in the vertical bolts, it is difficult to quantify the amount of bending present in the individual vertical bolts. The sudden acceleration in the transverse direction also causes axial stress reversals in the horizontal bolts, which are directly measured by the strain gauges. However, the effect of the axial stress reversals on the fatigue life usage of the horizontal bolts are not significant compared to the effect of bending stress on the fatigue life usage of the vertical bolts.



**Figure 6-8: Deformation of the cabin riser in the longitudinal direction**

Results from the FE model when an acceleration is applied in the forward (longitudinal) direction shown in Figure 6-8 above show very minimal displacements. This implies that an acceleration forward results in significantly minimal deflection of the riser body and walls when no loss in pretension of the bolts is assumed. The recorded measurement in the longitudinal direction of the displacement transducer also shows a very small displacement value, indicating that there is little to no relative movement between the chassis and the riser. Therefore, an acceleration in the forward direction occurring as a result of a sudden impact to the ground when a downward boom force is applied would not cause significant bending in the horizontal or vertical bolts.

Vertical displacement of the structure when an acceleration is applied in the vertical direction are shown Figure 6-9 below. Similar to the results obtained when the longitudinal acceleration is applied to the model in Figure 6-8, there is very minimal deflection present in the cabin riser wall adjacent to the chassis. Once again, the deformation in the FE model (at the location where the displacement transducer was installed) was compared against the measured value recorded by the displacement transducer on the machine. The displacement recorded by the transducer is larger than that observed in the FE model. This implies that the movement of the riser is taken by the horizontal bolts, forcing the bolts to bend.

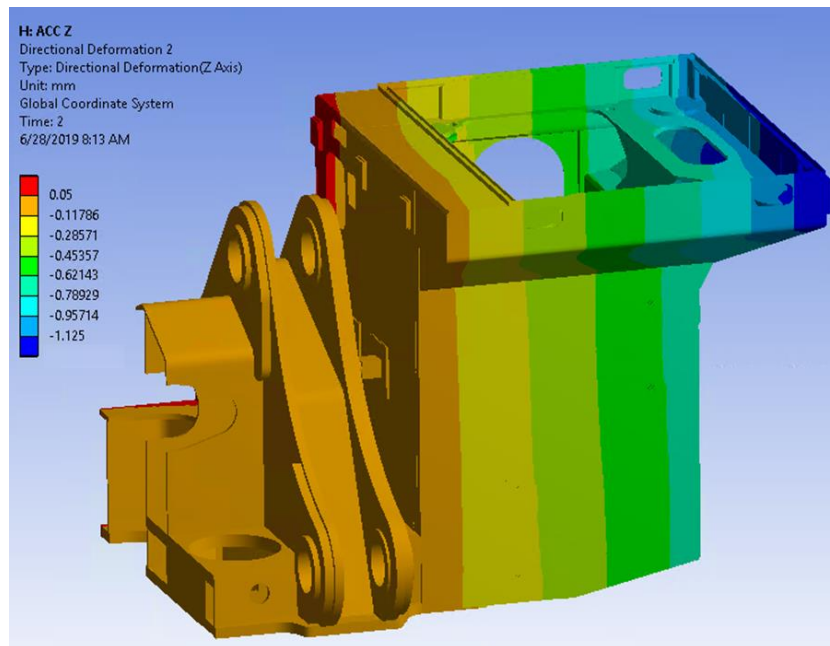

**Figure 6-9: Deformation of the cabin riser in the vertical direction**

Images of the failed horizontal bolts shown in Figure 4-4 indicate indentation of the bolt threads on the inside surface of the attachment block bore, which suggests that a slip between the interface of the attachment block and chassis mount of the horizontal bolts occurred. As discussed in Section 4.2.2, the riser would have had to be displaced more than 2.5mm to impact or have sufficient contact with the bolt threads. The loss of interface friction could be due to loss in pretension in the horizontal bolts, causing a large displacement compared to that measured by the SMS. The current pretension applied to both the horizontal bolts (SG03 and SG04) is shown in Table 5-1. This further places the importance in maintaining pretension in all bolts in the riser to avoid loss of interface friction which may result in fatigue crack propagation or failure of the attachment bolts.

## 7 OVERALL ASSESSMENT

### 7.1 INTRODUCTION

The BS7608 [5] was used to estimate fatigue life calculations based on a 10% probability of failure at the estimated life and that the operating conditions observed during the measurement period is a fair representative of the conditions experienced by the machine.

### 7.2 FATIGUE EXPECTATIONS UNDER CURRENT CONDITIONS

Fatigue life estimation was done considering the axial stresses alone which were measured by the strain gauges in the instrumented bolts and subsequently done incorporating both axial stresses and the bending stresses calculated based on results obtained from the measurements and FE analysis. The estimation of fatigue life of the bolts was done taking into account the factored stresses in the threaded section at the interface between the chassis and the bottom of 100x100 mm block attached to the riser, as reports show all bolts had failed at the same location. A rainflow analysis of the factored stresses in each bolt was done to obtain the equivalent stress used in fatigue life estimation calculation. The results of both cases are shown in Table 7-1 below.

**Table 7-1: Estimated fatigue life of attachment bolts and horizontal gauge SG12 on attachment block**

Bolt Notation	Instrumented Bolt	Estimated Fatigue Life (Hours)	
		Axial	Axial + Bending
B	SG01 – Vertical Bolt Front (Outer)	60000+	12500
A	SG02 – Vertical Bolt Front (Inner)	50000+	12500
E	SG03 – Horizontal Bolt Front	50000+	20000+
F	SG04 – Horizontal Bolt Rear	50000+	20000+
C	SG05 – Vertical Bolt Rear (Inner)	60000+	10000
D	SG06 – Vertical Bolt Rear (Outer)	20000+	4500
-	SG12 – Horizontal Gauge (Adjacent to Bolt E)	25000+	-

The fatigue life for the bolts considering axial stresses only (no bending present) are significantly higher than observed from failures and when both axial and bending stresses are present in the bolt. Results from FE modelling used for fatigue life estimation show that the sliding movement of the riser relative to the chassis is the main cause of bending in the bolts, which accounts for approximately 85% of the fatigue life usage.

The estimated fatigue life of the bolts varied significantly as the magnitude of stresses experienced by each bolt were different. Based on the SMS data recorded over the last three months, the outer rear bolt (Bolt D) has experienced the highest cumulative damage and hence had the lowest estimated fatigue life of approximately 4500 hours when both axial and bending stresses are considered. It should be noted that the pretension of Bolt D was significantly lower (approximately 27% of proof stress) than the pretension stress recommended by the OEM.

The fatigue analysis based on results from the FE model indicates that both the horizontal and vertical bolts experience bending. However, the fatigue damage due to bending and



axial loading in the horizontal bolts are significantly less compared to that experienced by the vertical bolts.

The low fatigue life estimated and observed implies that under normal operating conditions of the machine, the current bolt connection clearly allows bending of the bolts to occur. The fatigue life of the bolts should improve significantly if measures to ensure the recommended pretension stress in the bolts are achieved and where possible, the bolted connection geometry changed to reduce bending experienced by the bolts. Ensuring the recommended pretension is achieved will reduce fatigue damage mainly due to axial loading. Higher levels of pretension can facilitate friction grip at the riser and chassis interface and thereby reduce both interface slip and fatigue due to bending in bolts.

## 8 IMPROVEMENT STRATEGIES

### 8.1 POSSIBLE IMPROVEMENT OPPORTUNITIES - OPERATIONAL

Analysis of the SMS data together with information provided in the Fleet Management System (FMS) show that the regions with significantly high fatigue life usage and sudden increases in cumulative damage in the attachment bolts and boom structure coincide with periods where mostly coal was dug. The low fatigue life achieved when digging coal may be largely due to insufficient ground preparations. The coal dug in some areas of Mangoola mine may be inadequately shot or not ripped to aid the dig process. Consequently, operators are inclined to exert more force to dig ground, increasing the fatigue life usage of the machine.

Improved operator practices can be achieved through an operator training program and continuous real-time feedback through the SMS. A combination of good operator practices and adequate ground preparation will increase the life of the machine and avoid sudden propagation or initiation of cracks in the excavator structure, bolts and riser structure.

### 8.2 POSSIBLE IMPROVEMENT OPPORTUNITIES – BOLTED CONNECTIONS

The sliding movement of the riser is the main cause of bending in the bolts which accounts for 85% of the fatigue life usage. Ideally, the bolted connections should have been designed with a mechanism to lock the riser onto the chassis to prevent movement and reduce or eliminate bending in the bolts. A combination of improved operator practices and the suggested locking mechanism will result in a significant improve to the fatigue life of the attachment bolts and eliminate bolt failure. An example of the type of mechanism that could be used is shown below.

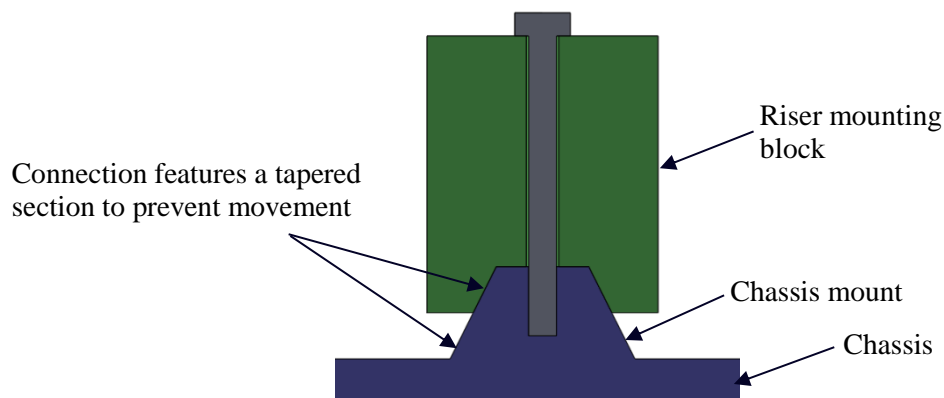

**Figure 8-1: The configuration above prevents sliding movement in the bolted connection of the riser**

As discussed in Section 4.2.2 of this report, investigations determined that the attachment arrangement of the riser to the chassis prevented replacement of four bolts that had already failed (i.e. bolts A, E, C and B). The broken bolt segments which remained inside the chassis mounts could not be extracted without detaching the entire cabin from the chassis, which would result in major down-time and loss of production. To avoid another potentially catastrophic failure, a bolt and nut arrangement should be considered to ease replacement of the bolts if needed. However, this may not be practical for all six bolts.

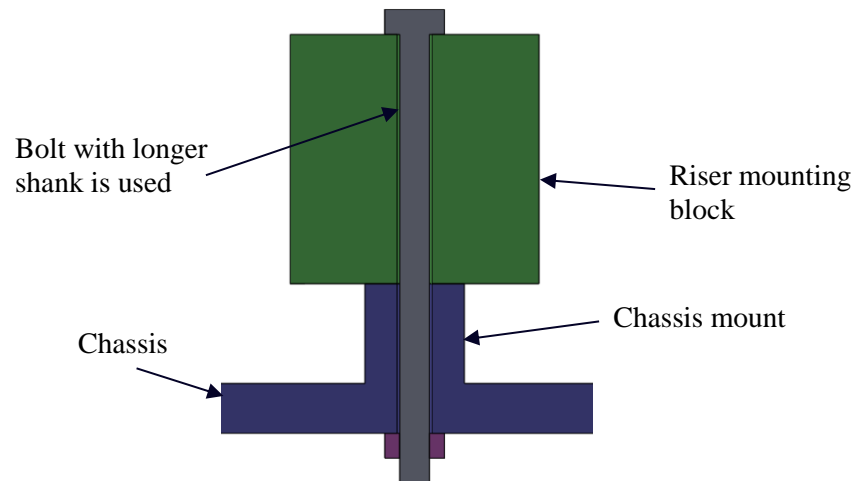

**Figure 8-2: Bolt and nut arrangement above would ease replacement of bolts in the occurrence of a failure**

## 9 CONCLUSIONS AND RECOMMENDATIONS

On the 10th October 2016, during normal coaling operations, the riser and the cabin of Leibherr R9250 Excavator (EX151) operating at Glencore Mangoola mine, separated from the chassis together as a unit, and tipped over to the side of the machine with the operator still inside the cabin. Attachment bolts had been failing in a sequence over a period of approximately 5 months leading up to the final complete detachment of the riser.

ICAM investigation was undertaken by Glencore Mangoola and a failure investigation on the two last failed bolts was undertaken by BV after the final failure.

Mangoola Mine commissioned MTI in late 2018 to undertake a detailed and independent investigation of the failure and to develop a comprehensive risk management strategy to eliminate such failures in the future.

MTI investigation consisted of: (i) review of available material and discussions with site staff; (ii) instrumentation and monitoring of the machine over a three-month period; (iii) modelling and analysis; and (iv) fatigue and other structural assessments.

The reports of the above two investigations, in addition to the general data on the machine were provided by the site for the investigation.

The SMS and additional instrumentation including instrumented bolts, accelerometers and displacement measurements were installed to record data during normal operations and by conducting specific tests.

The conclusions from the investigation are summarized below.

### *ICAM Report*

The ICAM report identified two main root causes: (i) misalignment between the riser and the chassis mounts; (ii) failure of the design and monitoring program to detecting the failing state of the interim repair.

It should be noted that none of the four broken bolts, out of the total of six bolts, could be replaced. Therefore, at the time of the final failure, the riser was attached with one horizontal bolt and one vertical bolt only. Some additional strengthening had been implemented to compensate for the missing bolts but seems to have been inadequate.

According to the findings of MTI investigation, root cause (i) above may have been caused due to the missing bolts.

The root cause (ii) above is valid and played a significant part in the final failure.

### *BV Report*

The following main conclusions can be made using the BV report contents combined with the MTI measurements and analysis.

- (i) Both failed bolts BV examined had signs of fatigue at the failure cross sections.
- (ii) The bolt material complied with the strength grade of Grade 10.9 specified by the OEM.
- (iii) Significant thread indentation marks on the bore of the riser attachment blocks were reported which were 35 mm diameter (compared to the bolt diameter of 30 mm). These indentation marks were present even in the bore of the very first bolt that failed, indicating that the riser was moving with respect to the chassis in the order of at least 2-3 mm even when all six bolts were in place. MTI measurements also found similar relative movement even after all the bolts were newly replaced and

tightened to the OEM specification. MTI analysis of the connection showed that bolts develop significant bending moments at the failed cross section due to this relative movement.

- (iv) Both bolts had failed at the riser and chassis interface of the attachment where bending stresses are maximum.
- (v) BV report also show wear marks on the bolts which are consistent with the relative movement described above.
- (vi) BV report also show the photographs of the chassis mounts (except for bolt A – see Figure 4-2) with the broken bolt segments still stuck inside the tapped holes. These photos show that the four bolts previously broken had not been able to be replaced. Therefore, at least over the last two months prior to final failure, the riser was attached to the chassis with only two bolts. The maintenance staff had attached some temporary brackets and additional welding to compensate for the four missing bolts. The details of these repairs were not available to assess their adequacy.

The conclusions (vi) and (vii) above are the main conclusions that can be drawn from the contents of BV report

#### *MTI Investigation*

The conclusions drawn from the MTI investigation are summarised below.

- (i) All the six bolts that attach the riser to the chassis were instrumented to measure the pretensions in the bolts and the dynamic axial loads attracted by the bolts during operations. The bolts were tightened according to the OEM specifications. The pretension value specified was 57% of proof stress, but the tightening procedure did not achieve this pretension uniformly in all six bolts. MTI conclude that the specified pretension is too low particularly considering the high relative movement between the riser and the chassis. Higher pretensions could activate better friction-grip between riser and chassis interface and reduce relative movement. Also a proper bolt tightening sequence is needed to bring all six bolts to the specified pretension.
- (ii) There is a down side in increasing the pretension while bolts are exposed to bending, because the pretension stresses and the bending stresses are additive at the potential failure cross section.
- (iii) The theoretical connection analysis undertaken showed that the bolts can be exposed to higher levels of fatigue loading when the pretensions are low. Therefore, proper pretensions should be maintained at all six bolted connections.
- (iv) The measurements made by the SMS showed that there are some operations of the machine that exert force/stress spikes on the structural system including the bolts. These forces are not likely to deform the structure to the extent of causing misalignment (as suggested by ICAM report), but can cause increased fatigue loading on the structural system including riser attachment bolts. The SMS which provides real-time feedback to operators can be used assist operators modify operating technique to minimise damage.
- (v) The analysis undertaken using the FEA, the measured relative displacements between chassis and the riser, and the measured bolt forces indicate that bolts are subjected to significant bending, in addition to the axial loads, due to the nature of the connection design. The relative movement between chassis and the riser and the resulting bending stresses in the bolts were a significant cause for the failure of the bolts. The fatigue assessment of bolts showed that the component of fatigue damage due to bending was as high as 85% of the total damage. A good connection design should eliminate the bending in the bolts. It has been shown by the theoretical model calculations in Section 6.1, that the bolts can be isolated from the dynamic axial load



cycles by using proper pretensions. No such isolation is possible to prevent bending fatigue damage in bolts if the relative movement between chassis and the riser is possible. Also, the maximum bending moment in bolts falls within the threaded part of the bolt where there is additional stress concentration due to the sharp geometry of the threads.

- (vi) Assuming the current connection design remains the same, and even if the pretension is increased and made uniform, the fatigue life of the bolts will remain relatively low. For practical purposes, maintenance arrangements should be planned assuming around 5000 hours of design life for the bolts. 89A bolt inspection and replacement scheme should be implemented to ensure bolts are not cracked or broken before scheduled replacement as cracked bolt may break during removal. Therefore, a conservative bolt replacement scheme and a frequent UT testing scheme for the bolts is needed.
- (vii) Another significant weakness in the riser attachment design is that if a bolt is broken and the broken segment of the bolt is embedded in the chassis mount, that segment cannot be removed to replace the bolt unless the entire assembly of the riser and the cabin is removed.

The following recommendations can be made to improve the life of the attachment bolts and minimise/eliminate risk of failure in the future:

- (a) Higher attention should be given to the pretension of the bolts. Currently, the OEM recommended pretension is set to 57% of proof stress which is too low. Increasing the recommended pretension closer to 90% of proof stress should be considered. However, this will be beneficial only if exposure of the bolts to bending is significantly reduced or prevented.
- (b) A pretension procedure to include a bolt pretension sequence and re-tightening processes to ensure all the bolts achieve the specified value correctly at the end of the pretensioning sequence be adopted.
- (c) The pretensions should be checked at the next scheduled service day after installation to ensure any pretension losses are rectified.
- (d) Until the bolted connect detail be modified to prevent bolt bending, it is recommended the bolts be replaced every 5000 hrs and an UT inspections be carried out every 3 months to avoid bolt crack initiation or failure.
- (e) Inspect areas of the attachment block adjacent to the horizontal bolts (locations of strain gauges SG11 and SG12) every 5000 hours. Cracks in these areas will lead to loss of pretensions in the horizontal bolts.
- (f) Conduct operator awareness training program utilising SMS data to eliminate strength alarms and reduce the number of fatigue alarms to improve production and minimise cumulative damage in the excavator and riser attachments.
- (g) Operating conditions should be monitored using the SMS and the data be used to trigger inspections/replacement of bolts.
- (h) Mangoola mine to ensure adequate ground preparations are carried out to minimise excessive force required by machine to dig hard ground.
- (i) The bolt connections between the riser and chassis should be redesigned to prevent movement of the riser with respect to the chassis which cause bending in the bolts. Alternatively, consider using a bolt and nut arrangement where feasible to facilitate easy replacement of a bolt in case of a bolt failure.

The inspection frequencies have been developed assuming that dig conditions and operator practices remain the same as observed during the investigation period. If the conditions/practices change the frequencies can be revised.

The SMS can be used to monitor the operating conditions and the data can be correlated to estimate bolt life even after the instrumentation used to measure the bolt stresses is removed.

## 10 REFERENCES

- [1] Coal Assets Australia, “Cab and riser of Liebherr R9250 separated from chassis, Document Number GCAA-1299732908-25,” Coal Assets Australia, Newcastle, 2016.
- [2] J. Turnbull, “16-2814073-1 Fractured Liebherr 9250 Excavator Cab Bolts,” Bureau Veritas, Newcastle, 2016.
- [3] S. Fernando, “An Engineering Insight To The Fundamental Behaviour of Tensile Bolted Joints,” *Steel Construction* , vol. 35, no. 1, pp. 2-7, 2001.
- [4] S. Fernando, “Mechanisms and Prevention of Vibration Loosening in Bolted Joints,” *Australian Journal of Mechanical Engineering*, vol. 2, no. 2, pp. 1-19, 2005.
- [5] *Fatigue Design and Assessment of Steel Structures*, BS 7608:1993 1993.

## **11 APPENDIX**

### **11.1 SMS INSTRUMENTATION LOCATIONS**

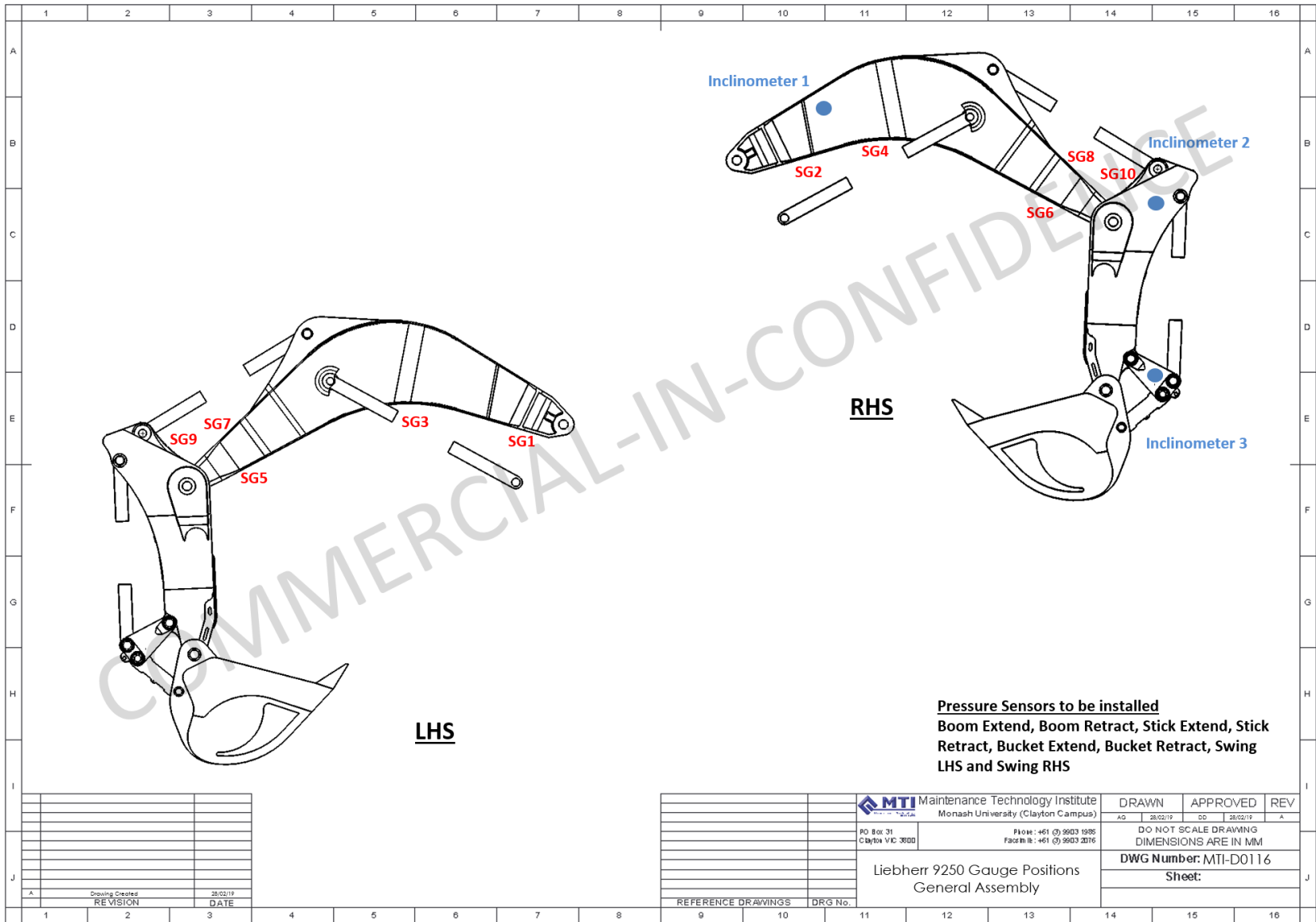

**LHS**

**RHS**

**Pressure Sensors to be installed**  
**Boom Extend, Boom Retract, Stick Extend, Stick Retract, Bucket Extend, Bucket Retract, Swing LHS and Swing RHS**

REVISION	DATE

REFERENCE DRAWINGS	DRG No.

**MTI** Maintenance Technology Institute  
 Monash University (Clayton Campus)

PO Box 31 Clayton VIC 3100

Phone: +61 (0) 9903 1995  
 Facsim: +61 (0) 9903 2176

Liebherr 9250 Gauge Positions  
 General Assembly

DRAWN	APPROVED	REV
AG	DC	A
28/02/19	28/02/19	
DO NOT SCALE DRAWING DIMENSIONS ARE IN MM		
DWG Number: MTI-D0116		
Sheet:		



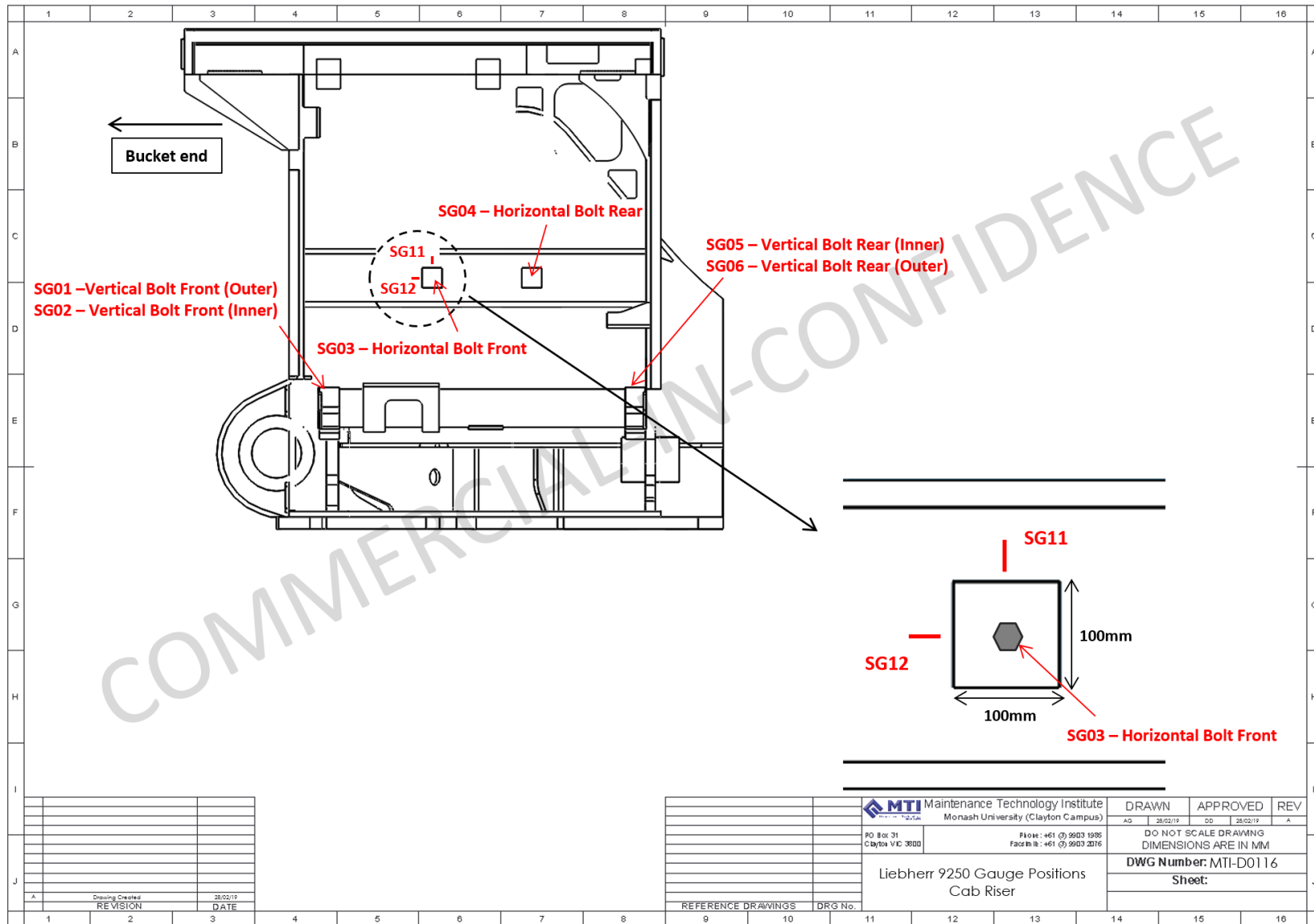

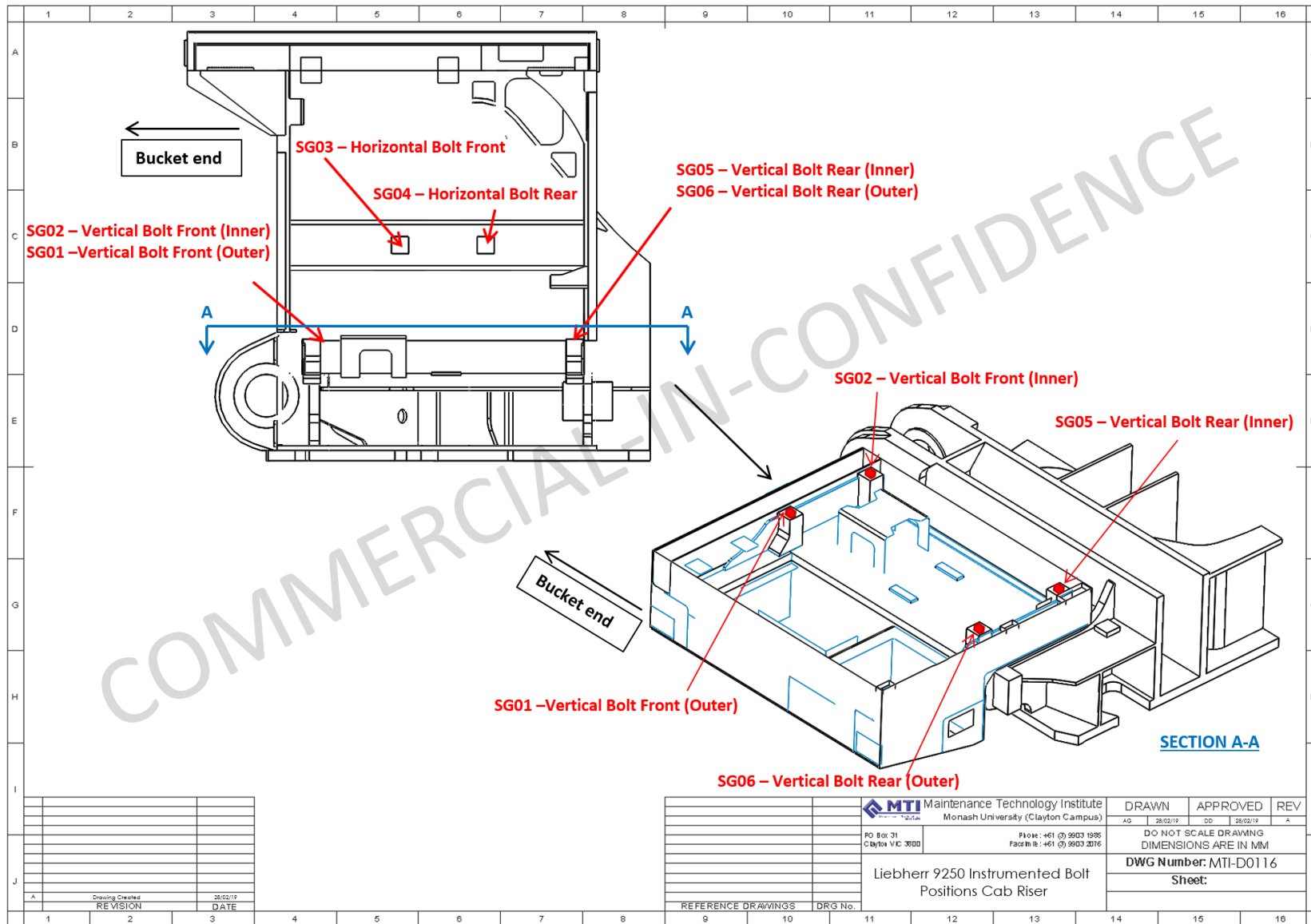

REVISION	DATE
A	28/02/19

REFERENCE DRAWINGS	DRG No.

Maintenance Technology Institute  
 Monash University (Clayton Campus)  
 PO Box 31 Clayton VIC 3168  
 Phone: +61 (0) 9903 1985  
 Fax: +61 (0) 9903 3016

DRAWN	APPROVED	REV
AG	DD	A
28/02/19	28/02/19	

DO NOT SCALE DRAWING  
 DIMENSIONS ARE IN MM  
 DWG Number: MTI-D0116  
 Sheet:

Liebherr 9250 Instrumented Bolt  
 Positions Cab Riser

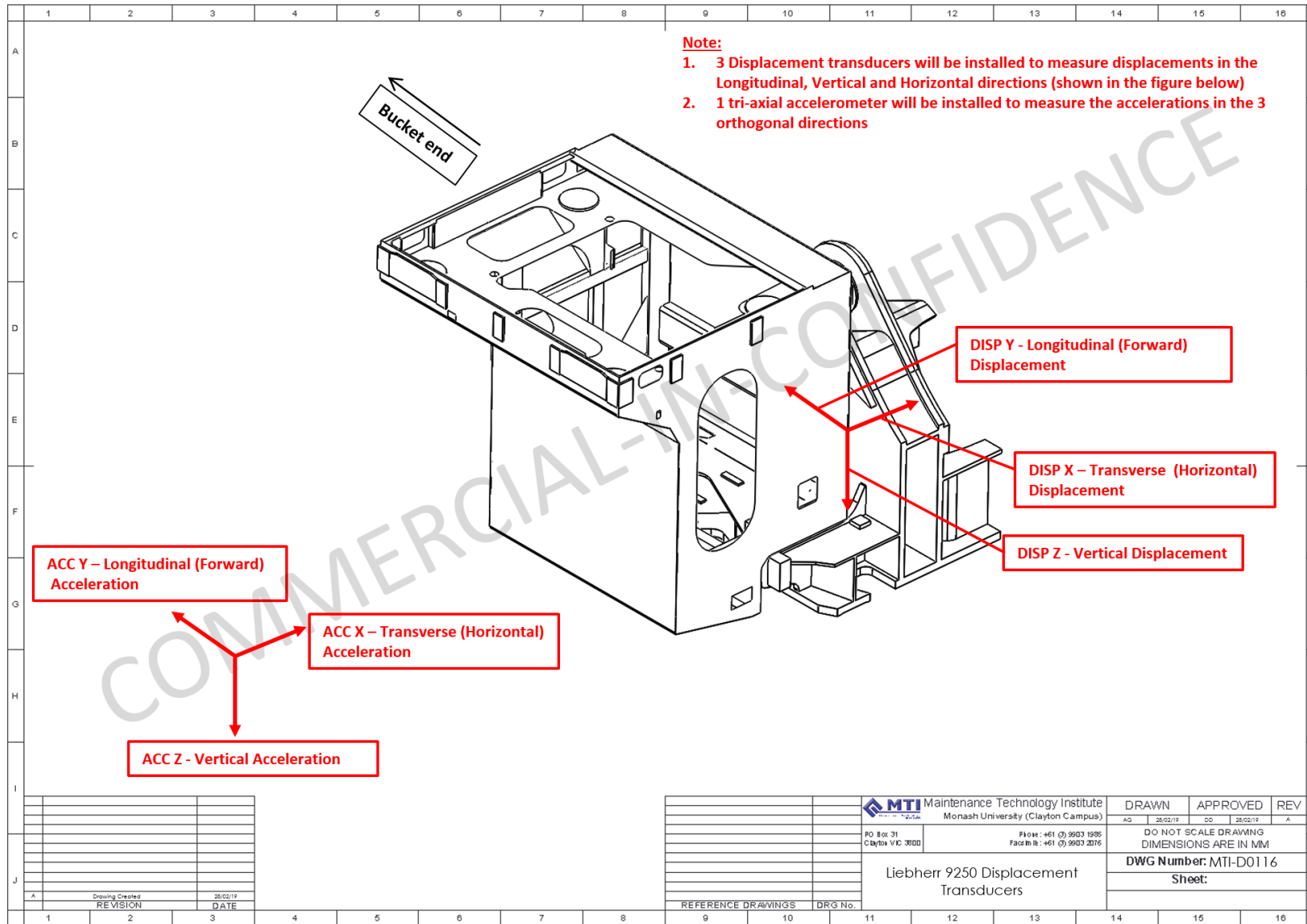

## **11.2 SMS 40 HZ DATA SAMPLES**

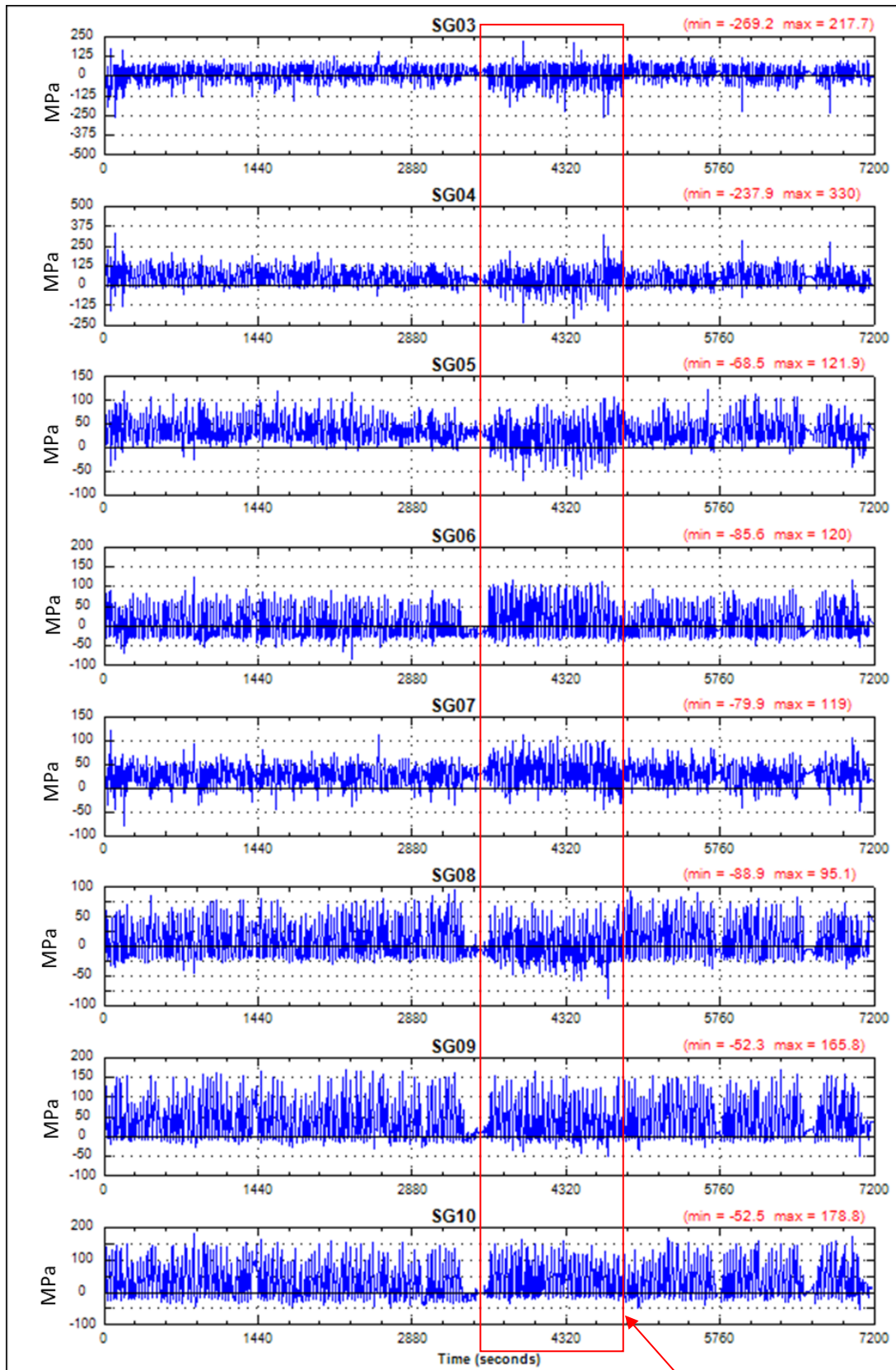

Sudden impact with side load to break ground and scraping before start of dig

Figure 11-1: SMS Strain Gauge Data - 24th April 2019 10:00PM.



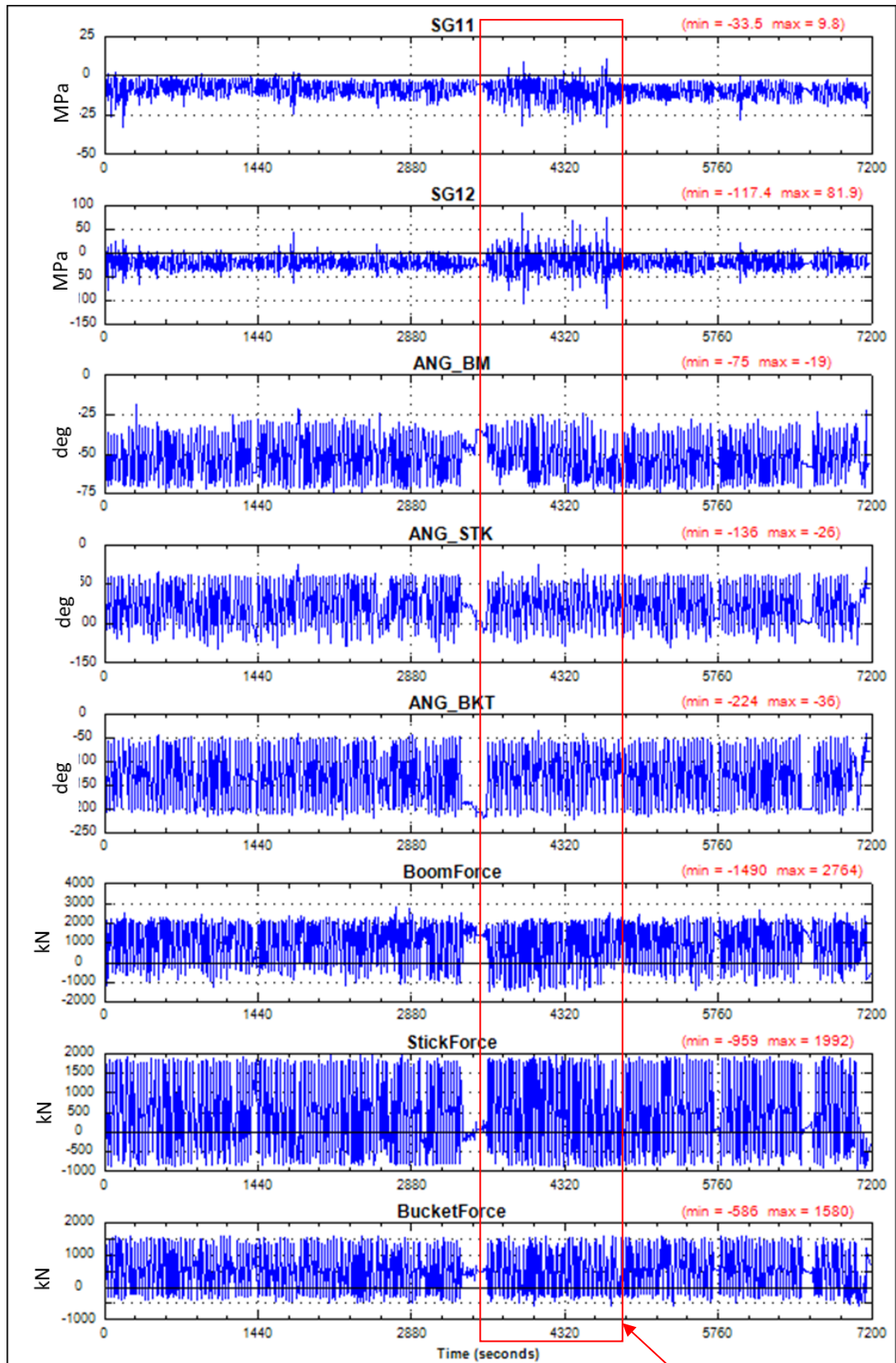

Sudden impact with side load to break ground and scraping before start of dig

Figure 11-1 (Continued): SMS Strain Gauge Data - 24th April 2019 10:00PM.

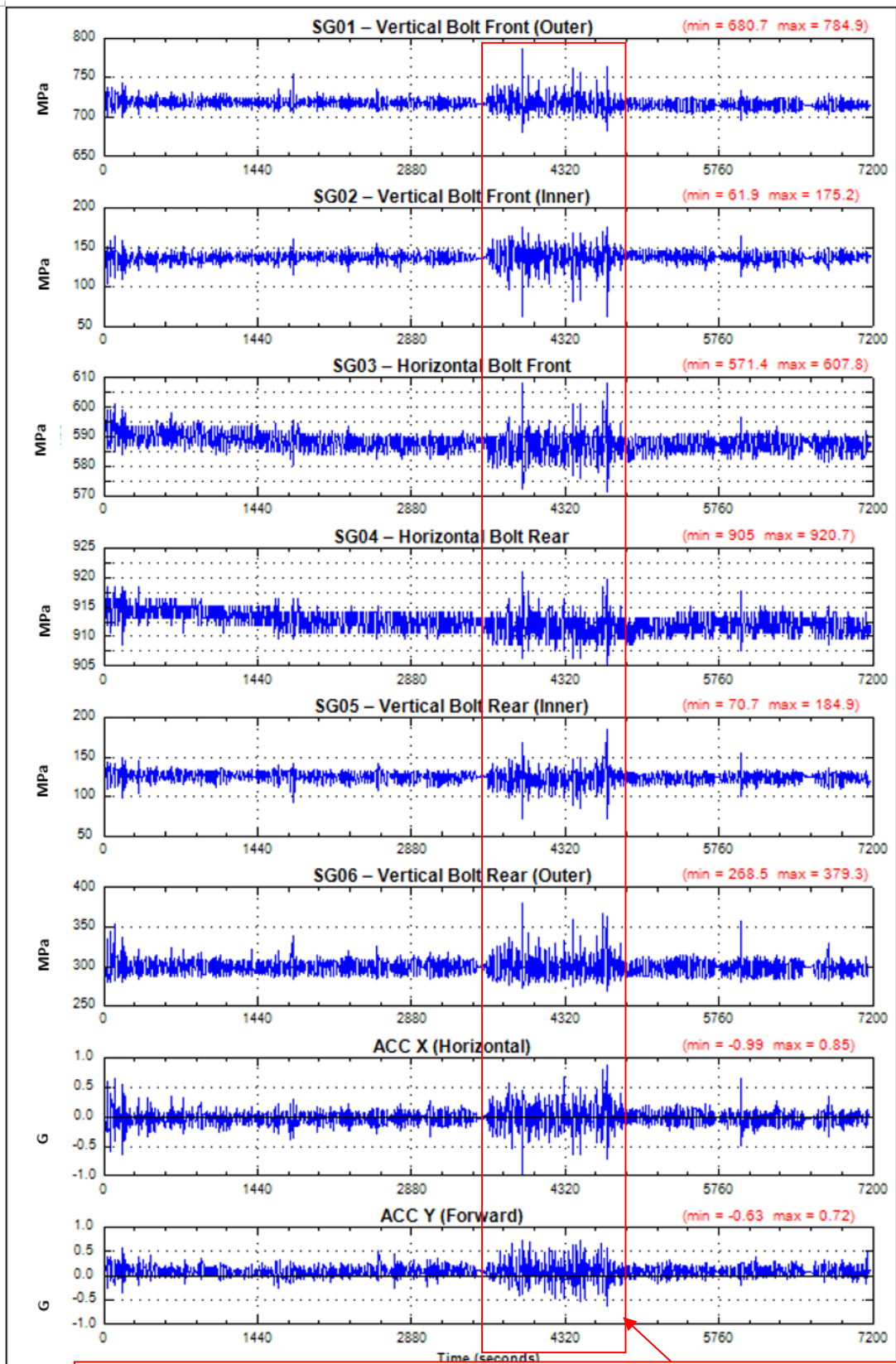

Sudden impact with side load to break ground and scraping before start of dig

Figure 11-2: Instrumented Bolts, Accelerometer and Displacement Transducer Data - 24th April 2019 10:00PM.

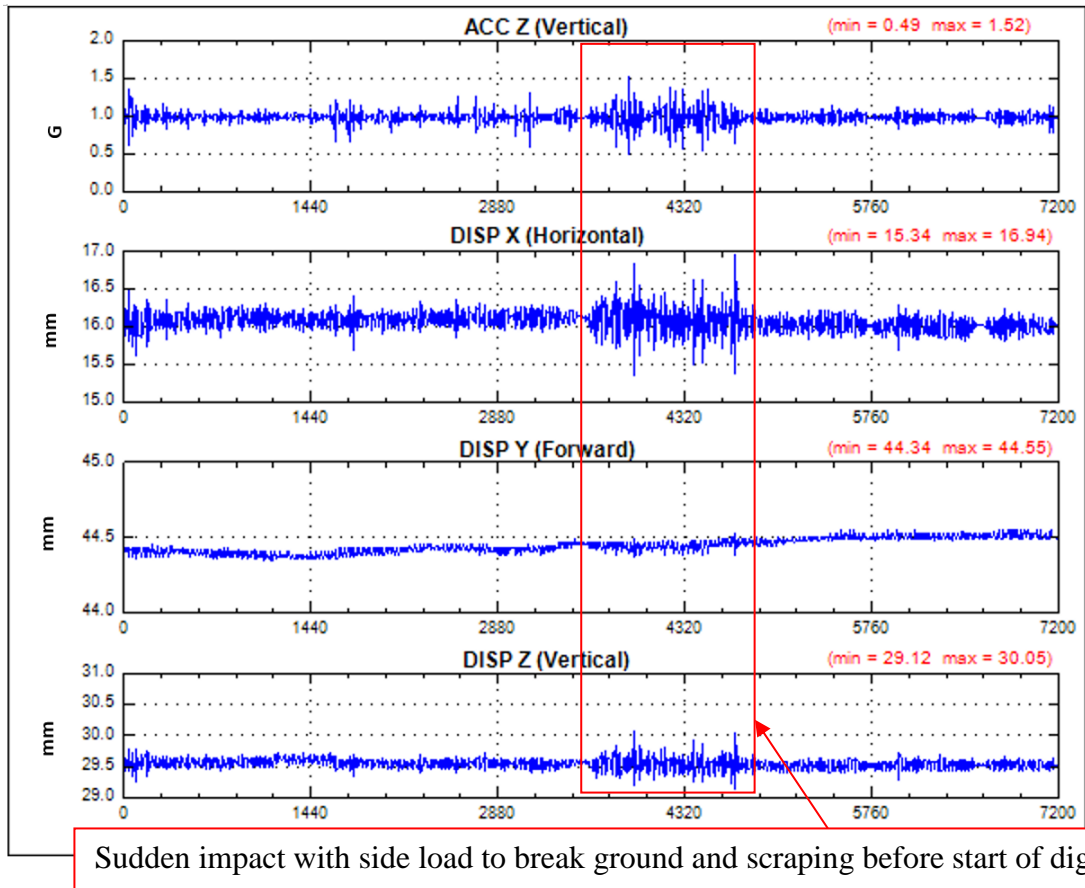

Figure 11-2 (Continued): Instrumented Bolts, Accelerometer and Displacement Transducer Data - 24th April 2019 10:00PM.

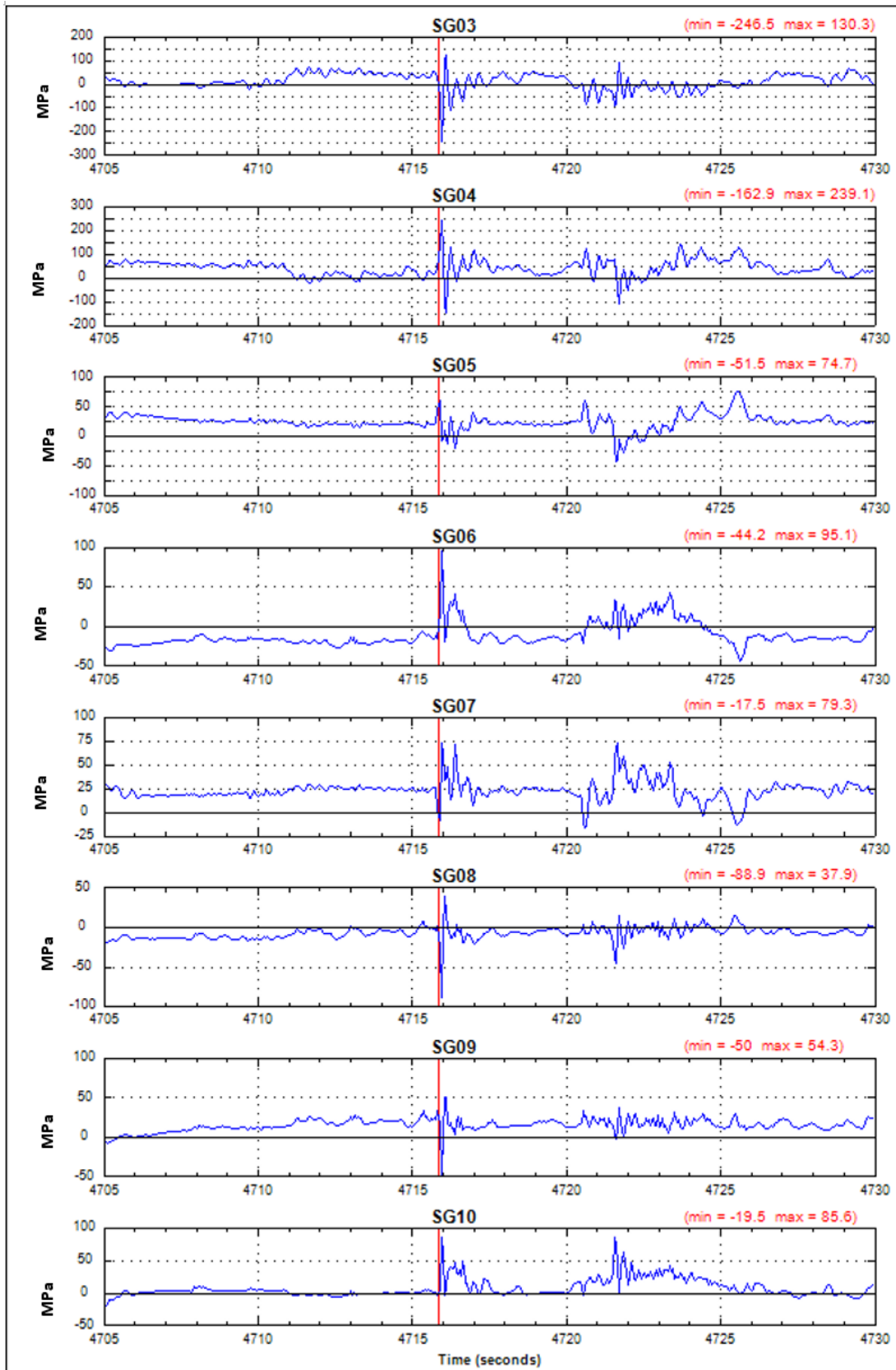

Figure 11-3: SMS Strain Gauge Data - 24th April 2019 10:00PM- Machine digging coal

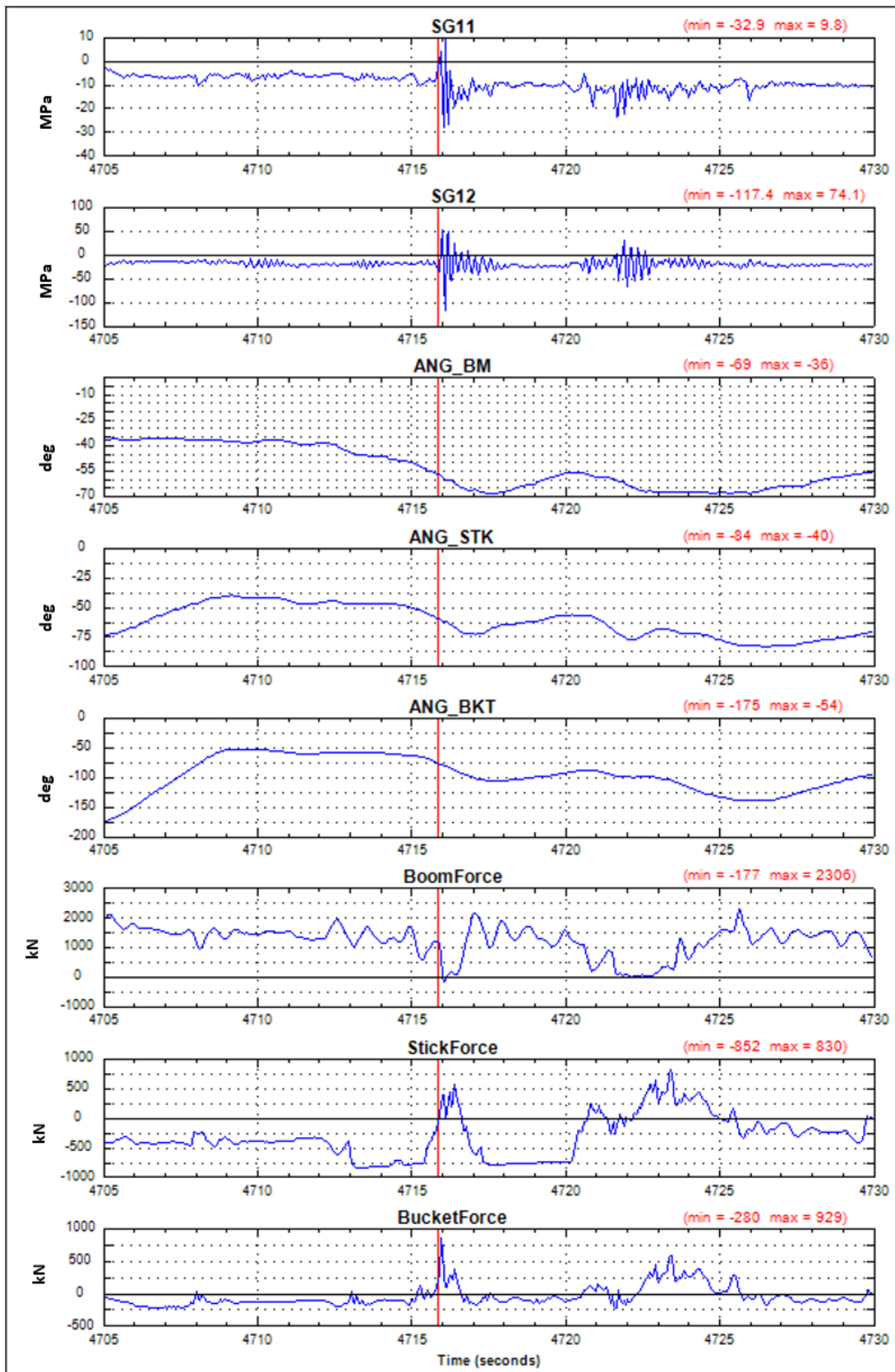

Figure 11-3 (Continued): SMS Strain Gauge Data - 24th April 2019 10:00PM- Machine digging coal



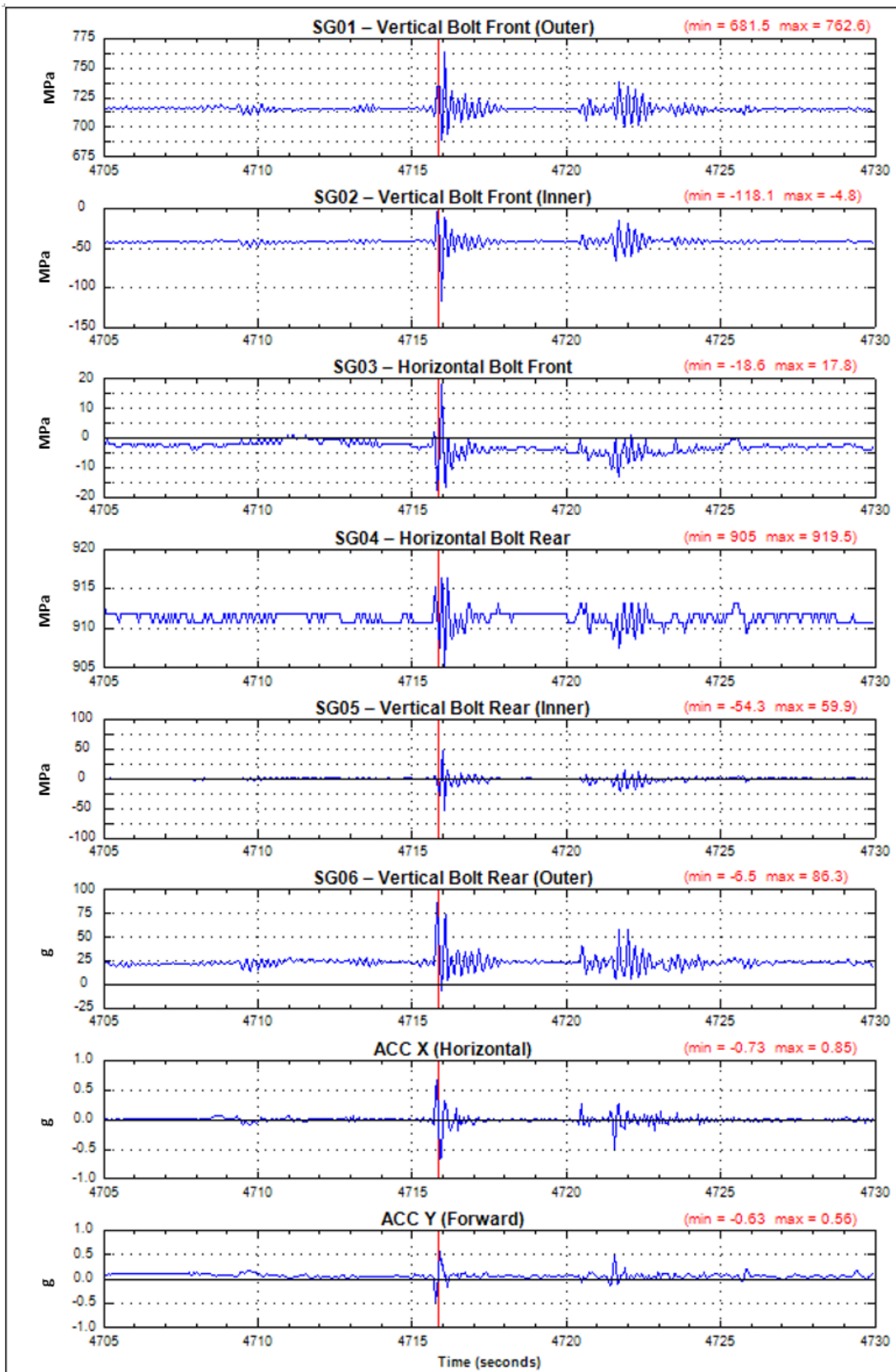
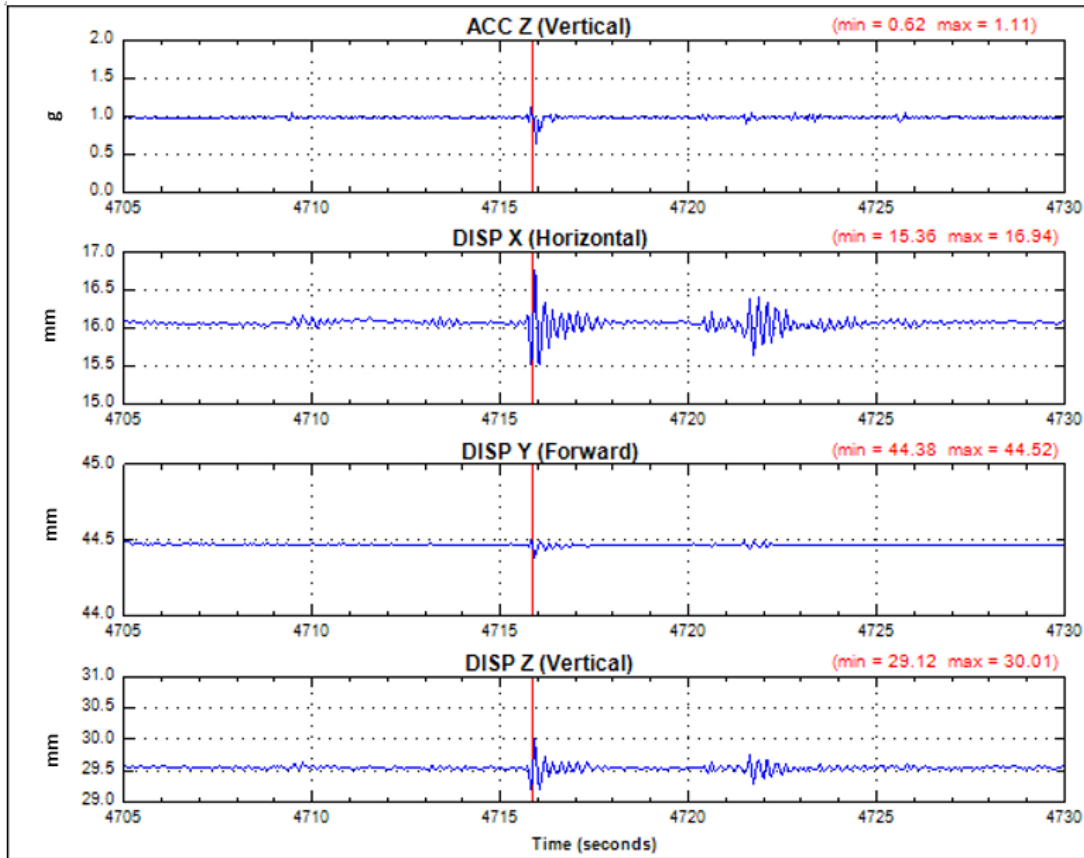
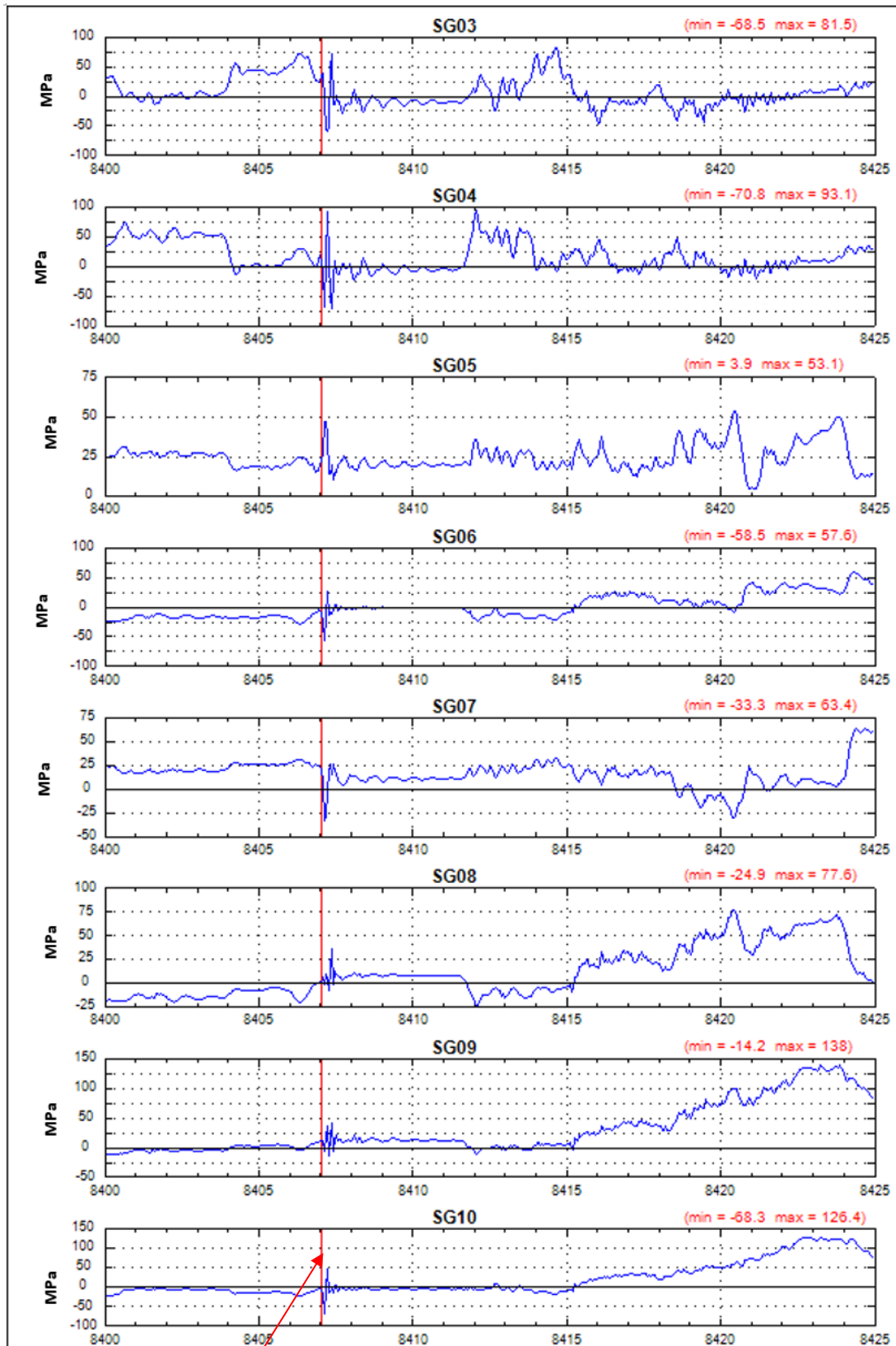

Figure 11-4: Instrumented Bolts, Accelerometer and Displacement Transducer Data - 24th April 2019 10:00PM - Machine digging coal



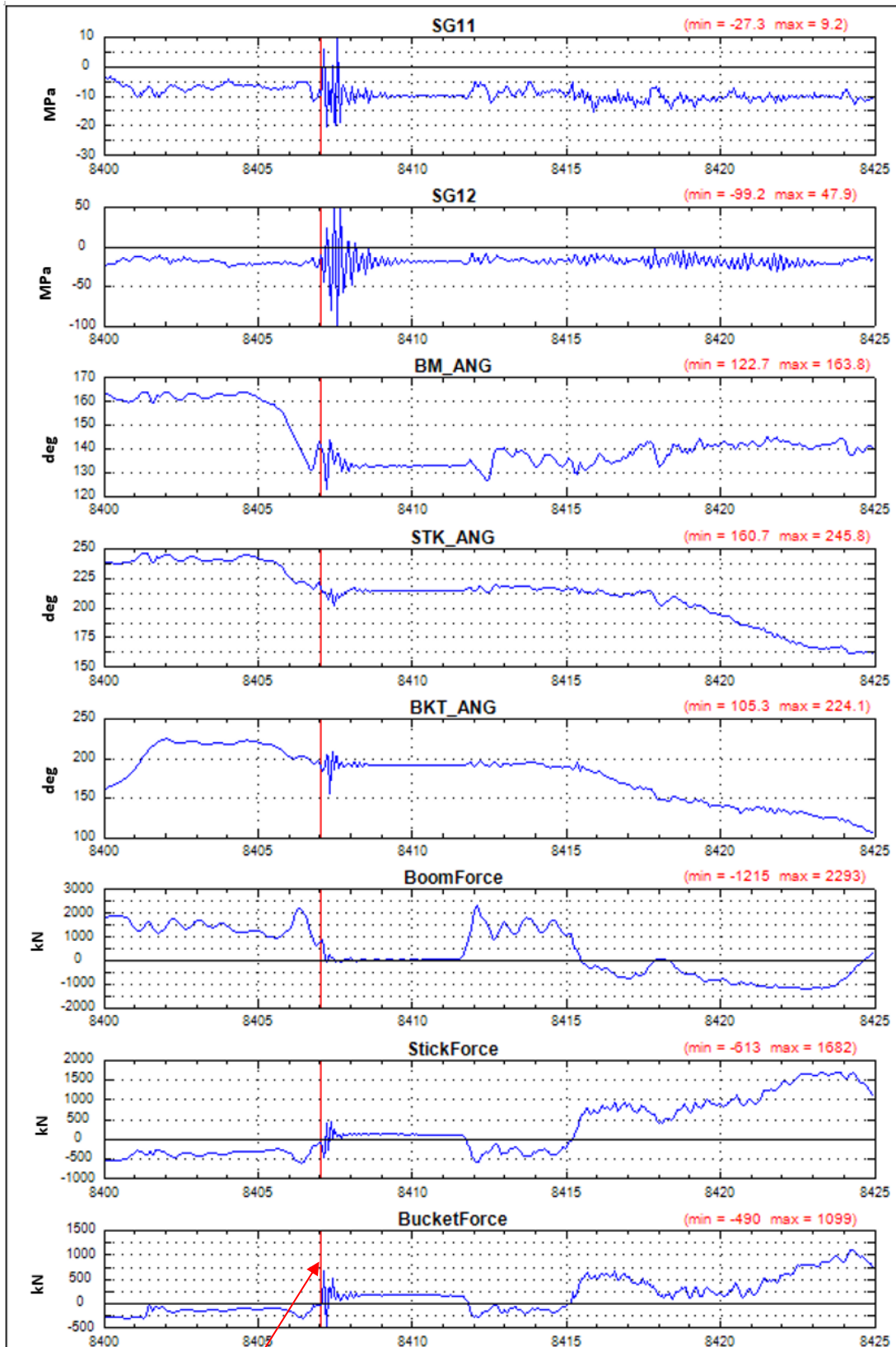

**Figure 11-4 (Continued): Instrumented Bolts, Accelerometer and Displacement Transducer Data - 24th April 2019 10:00PM - Machine digging coal**



Sudden impact due to causing vibrations and stress reversals throughout structure

Figure 11-5: SMS Strain Gauge Data – Impact Testing 21<sup>st</sup> May 2019 9:20AM.



Sudden impact due to causing vibrations and stress reversals throughout structure

Figure 11-5 (Continued): SMS Strain Gauge Data – Impact Testing 21st May 2019 9:20AM.

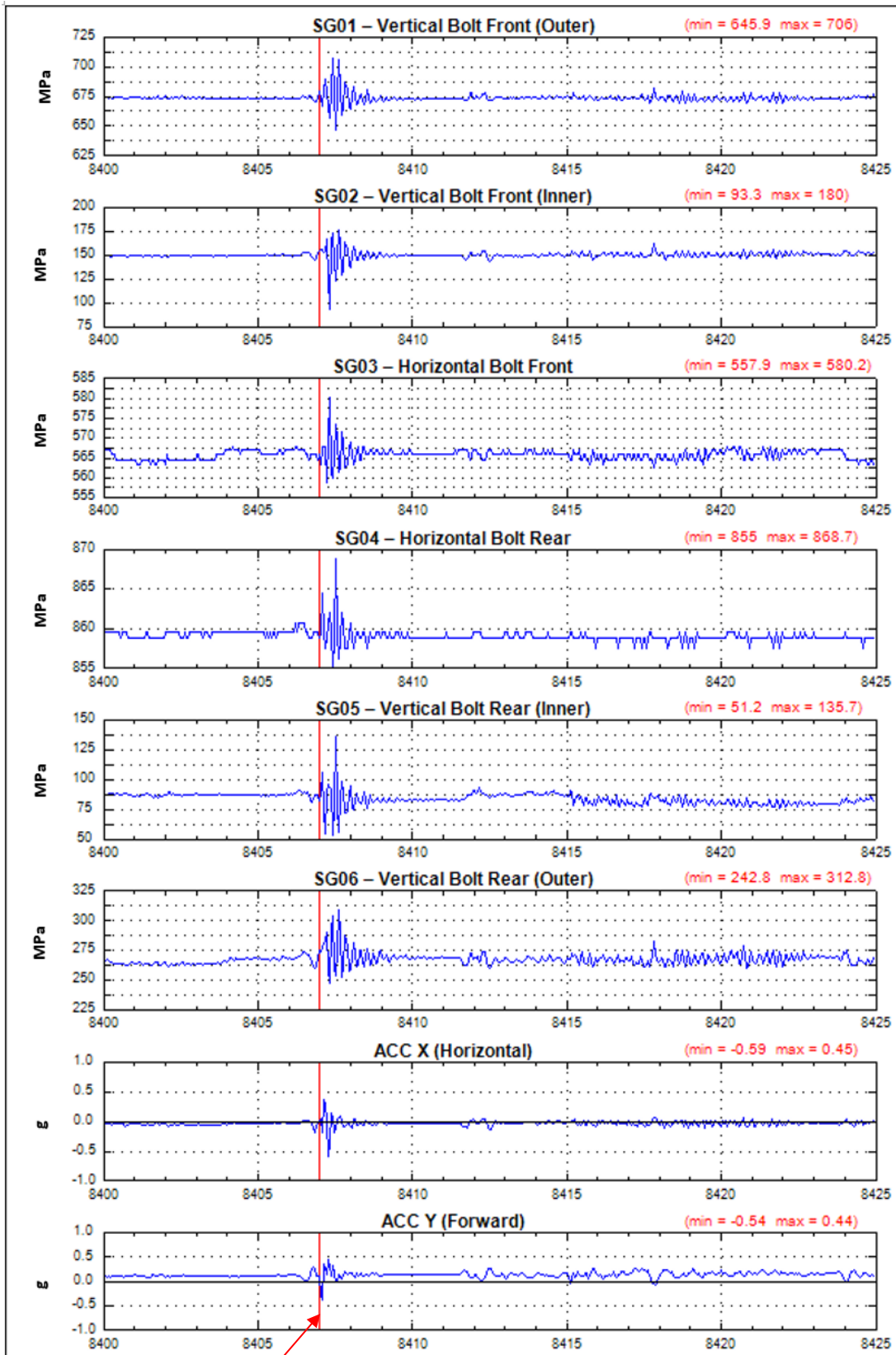

Sudden impact due to causing vibrations and stress reversals throughout structure

Figure 11-6 : Instrumented Bolts, Accelerometer and Displacement Transducer Data – Impact Testing 21st May 2019 9:20AM.

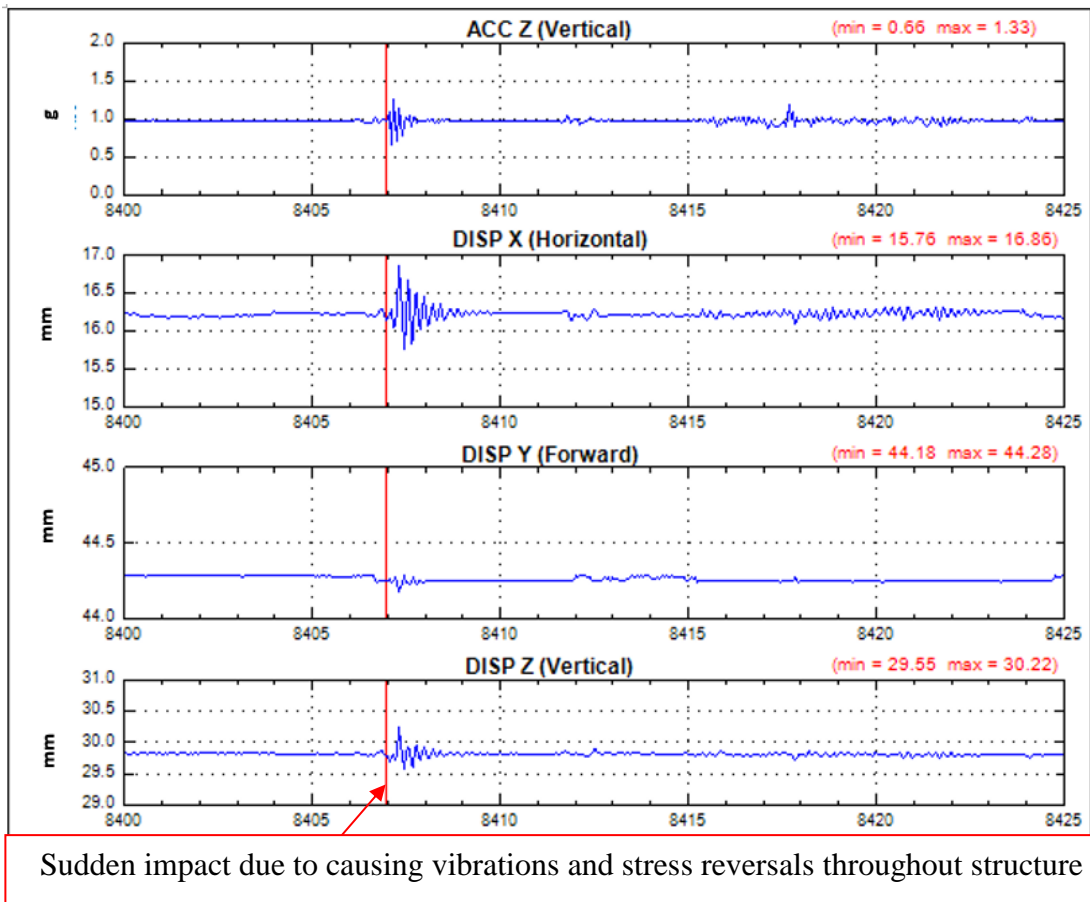

**Figure 11-6 (Continued): Instrumented Bolts, Accelerometer and Displacement Transducer Data – Impact Testing 21st May 2019 9:20AM.**

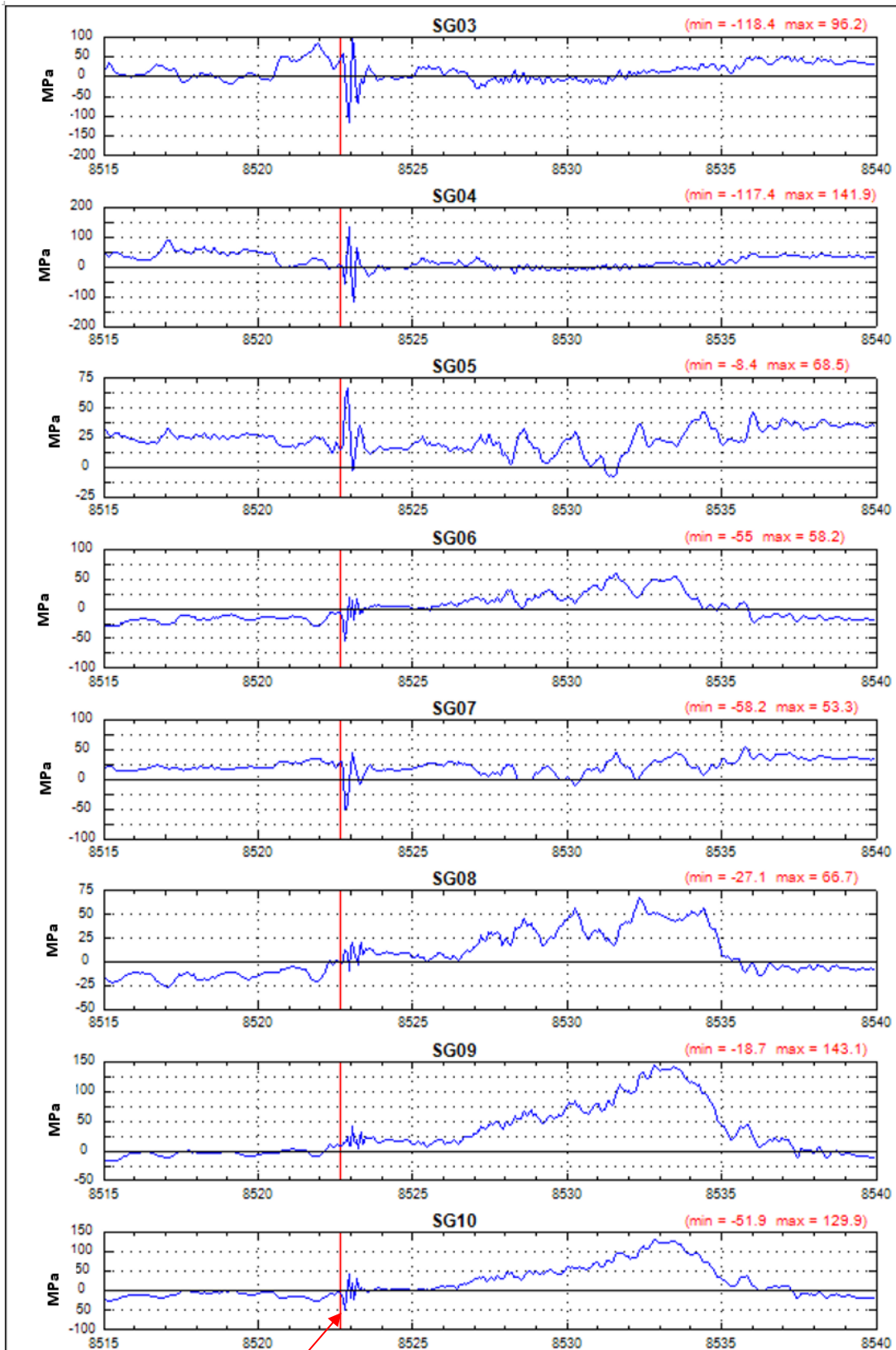

Large spikes showing bending due to downward boom force and side load application

Figure 11-7: SMS Strain Gauge Data – Impact Testing 21st May 2019 9:22AM.



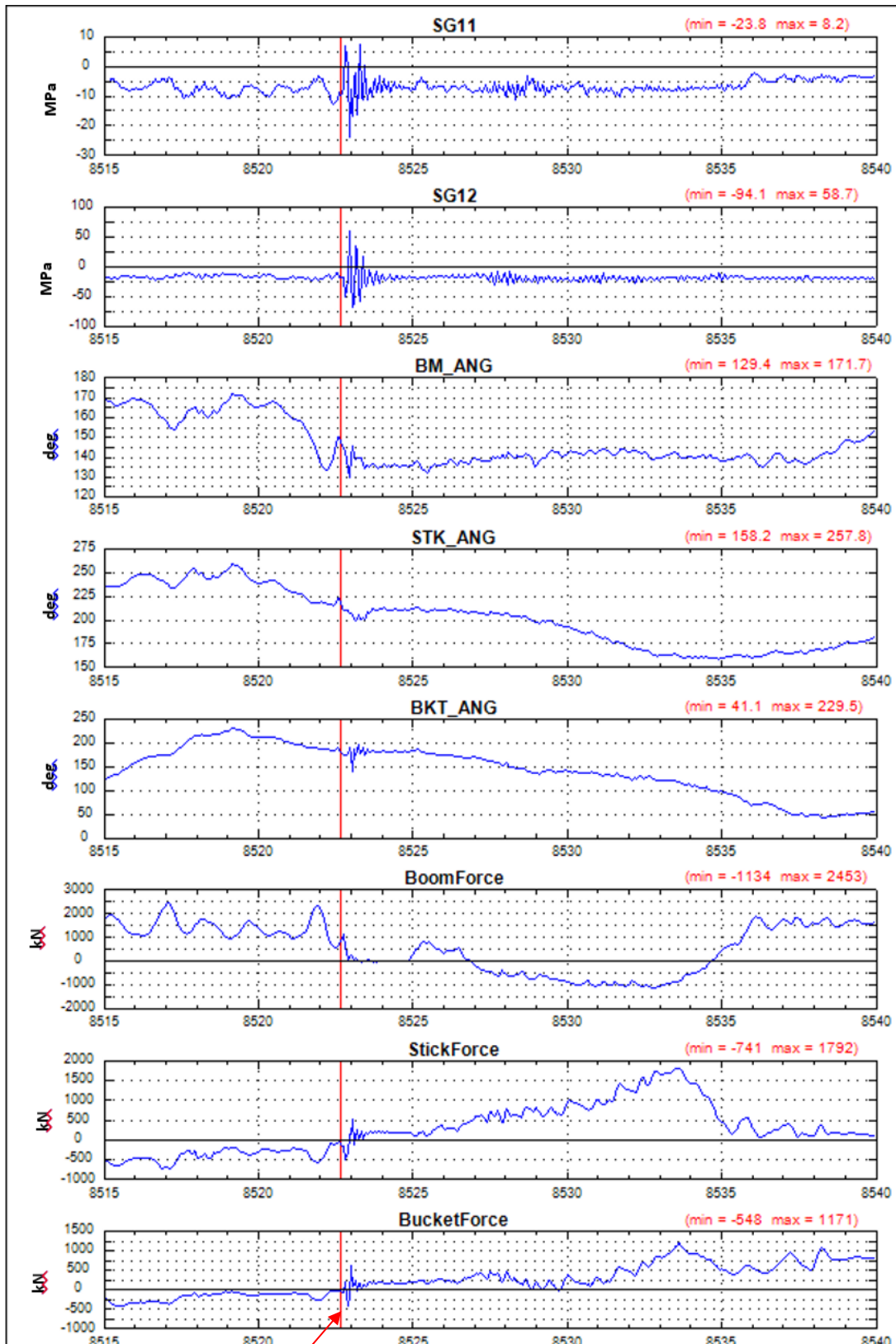

Large spikes showing bending due to downward boom force and side load application

Figure 11-7 (Continued): SMS Strain Gauge Data – Impact Testing 21st May 2019 9:22AM.

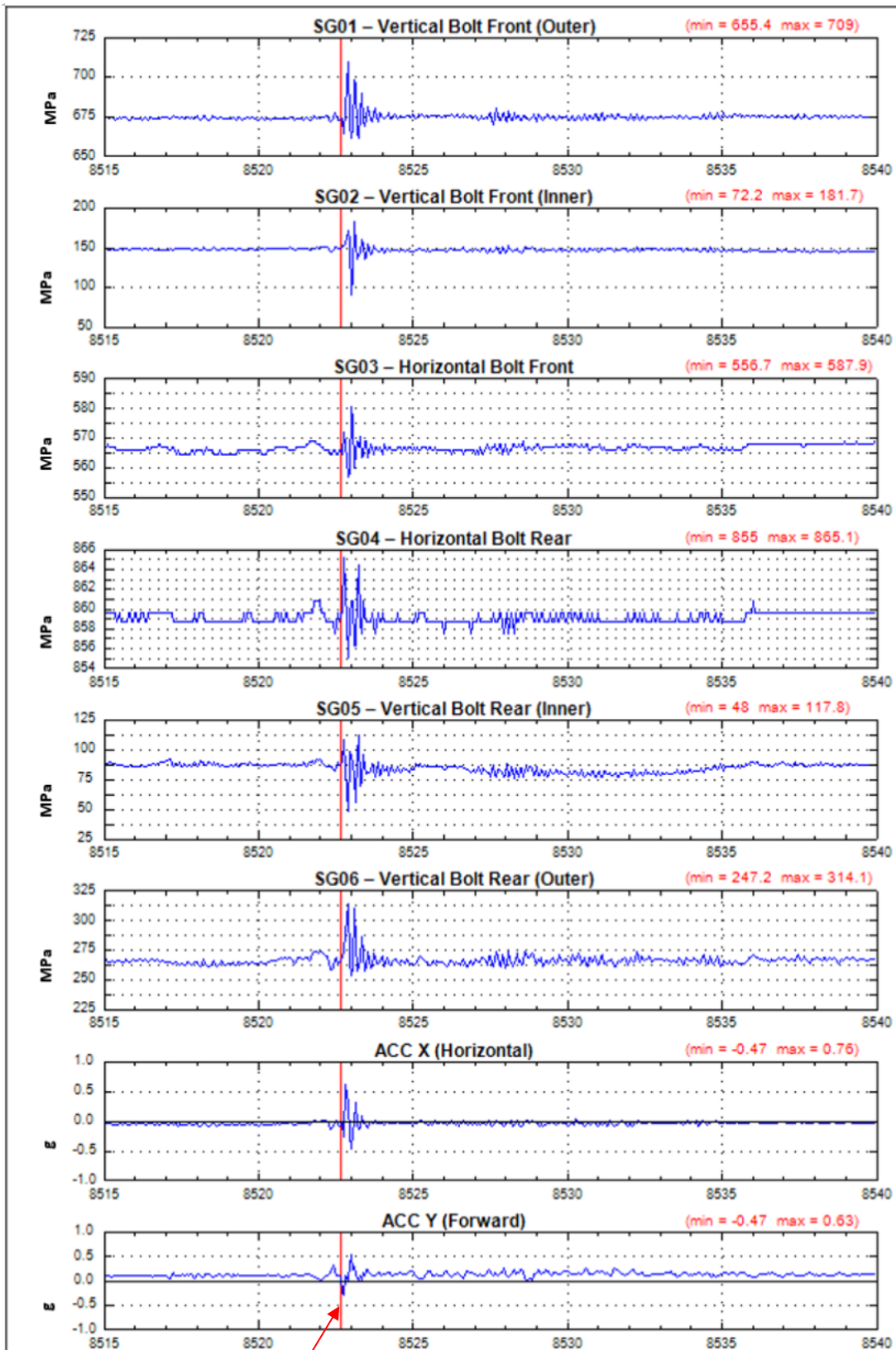

Large spikes showing bending due to downward boom force and side load application

Figure 11-8: Instrumented Bolts, Accelerometer and Displacement Transducer Data – Impact Testing 21st May 2019 9:22AM.

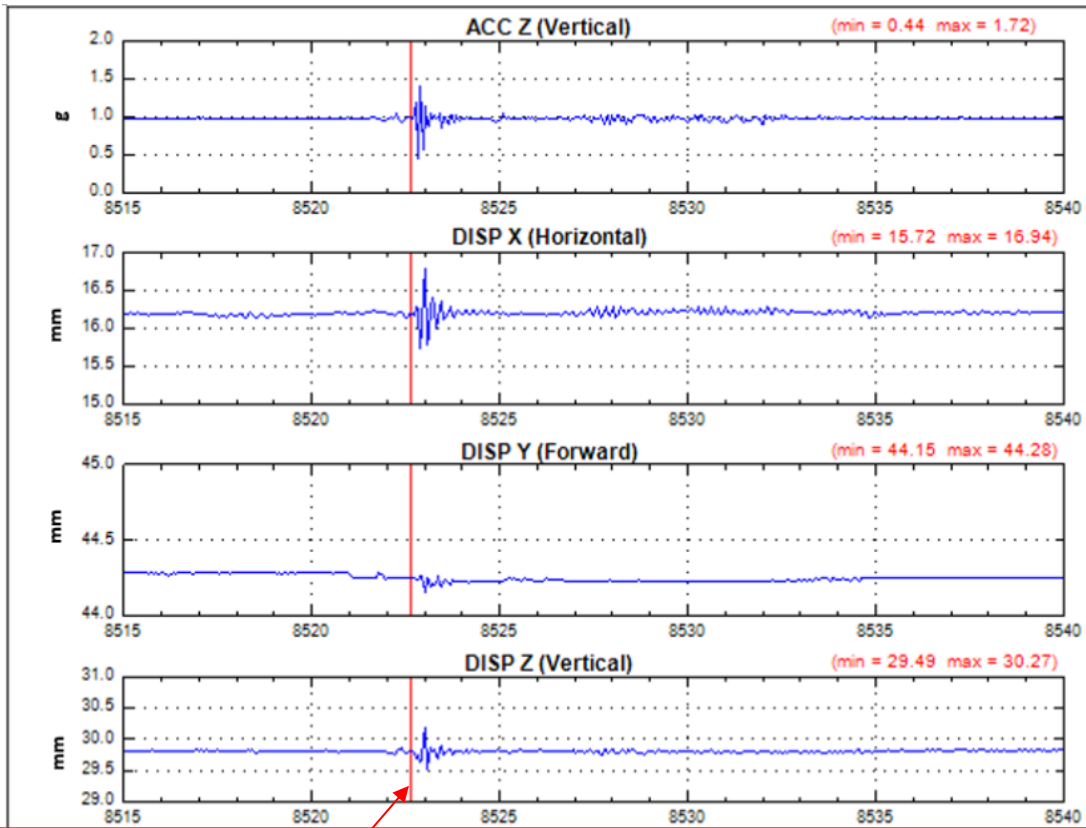

Large spikes showing bending due to downward boom force and side load application

Figure 11-8 (Continued): Instrumented Bolts, Accelerometer and Displacement Transducer Data – Impact Testing 21st May 2019 9:22AM.

## Addendum to report prepared by the Maintenance Technology Institute: *Liebherr R9250 Riser Detachment Failure at Glencore Mangoola Mine*

### Compliance map for risk assessing temporary repairs to mobile plant used in mining

#### Background

This compliance map has been prepared as part of an enforceable undertaking entered into by Mangoola Coal Operations Pty Ltd (**Mangoola**) with the New South Wales Department of Planning and Environment on 25 September 2018.

The enforceable undertaking was provided in response to an incident which occurred at the Mangoola open cut coal mine on 10 October 2016. The incident occurred when the cabin and riser of a Liebherr brand R9250 excavator (**Excavator**) dislodged and tipped off the chassis. The cabin came to rest on the tracks of the excavator. Prior to the incident:

- Three vertical bolts and one horizontal bolt were progressively identified as broken from 13 May 2016 to 12 August 2016.
- Three interim repairs were conducted on the Excavator with the aim of securing the cabin, and an inspection program was put in place to monitor the condition of the interim repairs with a view to conducting permanent repairs during a scheduled maintenance shutdown planned for November 2016.

#### Purpose of this compliance map

This compliance map provides general guidance to duty holders on assessing risks arising from temporary repairs to mobile plant used in mining and identifying and implementing controls to eliminate so far as reasonably practicable or minimise those risks.

The focus of this compliance map is on the work health and safety obligations of the operator of a mine as the user of the mobile plant. The content of this document is general in nature and is not intended as legal advice, nor as an exhaustive statement of the obligations which may apply to persons with duties under the relevant laws. You should not rely on the contents of this document. You should always seek specific legal advice on your specific circumstances.

This document references Model Codes of Practice, as approved by Safe Work Australia, which should be consulted for further and specific advice regarding how to manage work health and safety risks. Further regard may be had to other regulatory guidance materials, standards and codes practice published by Australian Commonwealth, State and Territory and international safety regulators.

The term “*person conducting a business or undertaking*” (**PCBU**) has been used in this document to refer to persons who are both a PCBU for the purposes of the *Work Health and Safety Act 2011* (NSW) (**WHS Act**), and an “*operator*” of a mine under the *Work Health and Safety (Mines and Petroleum Sites) Regulation 2014* (NSW) (**Mining Regulations**). Where the PCBU and the operator of a mine are not the same person, distinct and separate duties may apply.

**1. Identify hazards and assess risks**

Any temporary repairs to mobile plant must be risk assessed before being implemented, consistent with the obligations of duty holders under the WHS Act and in accordance with the specific requirements under the *Work Health and Safety Regulation 2017* (NSW) (**WHS Regulations**) and the Mining Regulations.

A proposed repair may be risk assessed by multiple duty holders depending on the precise nature of the repair proposed and the position of each duty holder (for example, where the designer of the proposed repair is not the PCBU). A risk assessment must take into account the overall design of the mobile plant and any component parts, the reasons why the repair is being undertaken and the purpose for which the mobile plant will be used (and the conditions it will be used in) following the repair. The risk assessment must plan (or consider any existing plans) for how the temporary repair is to be carried out.

Depending upon the nature of the temporary repair, it may be appropriate to engage a specialist contractor or expert to provide advice on the proposed temporary repair and consider such advice as part of the risk assessment.

For duty holders other than the PCBU (in this circumstance, designers, manufacturers, importers, suppliers and persons who install, construct or commission plant), this also includes obligations to provide the relevant PCBU with information regarding relevant hazards or risks that you have identified or been made aware of.

Duty holder to whom this obligation applies		Relevant provisions of the WHS Act	Relevant provisions of the WHS Regulations	Relevant provisions of the Mining Regulations	Applicable codes of practice
a)	PCBU	s 19	cl 34 & 203	cl 9	Safe Work Australia, <i>Model Code of Practice: How to Manage work health and safety risks</i>
b)	Designer	s 22	cl 34 & 187	-	
c)	Manufacturer	s 23	cl 34 & 193	-	Safe Work Australia, <i>Model Code of Practice: Managing the risks of plant in the workplace</i>
d)	Importer	s 24	cl 34, 196 & 197	-	
e)	Supplier	s 25	cl 34 & 198	-	

f)	Person who installs, constructs or commissions plant	s 26	cl 34 & 201	-	
----	--	------	-------------	---	--



<b>2. Identify controls</b>					
<p>Once a proposed temporary repair has been risk assessed, the control measures for eliminating so far as reasonably practicable or minimising any hazards or risks need to be identified and assessed to determine whether they are reasonably practicable to implement. For duty holders other than the PCBU (in this circumstance, designers, manufacturers, importers, suppliers and persons who install, construct or commission plant), this also includes obligations to provide the PCBU with information regarding relevant control measures that you have identified or been made aware of.</p>					
<b>Duty holder to whom this obligation applies</b>		<b>Relevant provisions of the WHS Act</b>	<b>Relevant provisions of the WHS Regulations</b>	<b>Relevant provisions of the Mining Regulations</b>	<b>Applicable codes of practice</b>
a)	PCBU	s 19	cl 36, 203 – 206 & 214	cl 9(5) & 28	Safe Work Australia, <i>Model Code of Practice: How to Manage work health and safety risks</i>  SafeWork Australia, <i>Model Code of Practice: Managing the risks of plant in the workplace</i>
b)	Designer	s 22	cl 36 & 187 – 192	-	
c)	Manufacturer	s 23	cl 36 & 193 – 195	-	
d)	Importer	s 24	cl 36 & 196 – 197	-	
e)	Supplier	s 25	cl 36 & 198	-	
f)	Person who installs, constructs or commissions plant	s 26	cl 36 & 201	-	





### 3. Consult with other duty holders (and workers)

Before implementing any proposed controls, or the proposed temporary repair, the person proposing to undertake the repair must consult other duty holders who have duties in relation to the mobile plant regarding the proposed repair and controls. This is particularly important in circumstances where the person proposing to undertake the repair is not the designer or the manufacturer of the plant and/or where the proposed repair results in changes to the design of the plant. This is an ongoing obligation.

A PCBU must also consult its workers in relation to the controls that are proposed to be implemented.

Duty holder to whom this obligation applies		Relevant provisions of the WHS Act	Relevant provisions of the WHS Regulations	Relevant provisions of the Mining Regulations	Applicable codes of practice	
a)	All duty holders with a duty in relation to the temporary repair.	s 46	-	-	Safe Work Australia, <i>Model Code of Practice: Work health and safety consultation, cooperation and coordination</i>	
<b>Specific consultation obligations</b>						
b)	Manufacturer	s 46	cl 193(c)(iii)	-		
c)	Importer	s 46	cl 197(d)	-		
d)	PCBU (in relation to the duty to consult workers)	ss 47 - 49	-	-		



### 4. Implement controls

After consulting other duty holders regarding the proposed repair and controls, the PCBU must ensure that the controls are implemented (so far as is reasonably practicable) before, during and after the period in which the temporary repair is undertaken (which may include ensuring that other duty holders take steps to implement the relevant controls). Where a duty holder other than the PCBU is required to implement a control, the duty holder must consult, co-operate and co-ordinate activities with other duty holders (see s 46 of the WHS Act). This is in addition to their obligations to provide information regarding relevant controls.

Duty holder to whom this obligation applies		Relevant provisions of the WHS Act	Relevant provisions of the WHS Regulations	Relevant provisions of the Mining Regulations	Applicable codes of practice
a)	PCBU	s 19	cl 203 - 215	cl 9	Safe Work Australia, <i>Model Code of Practice: How to Manage work health and safety risks</i>  SafeWork Australia, <i>Model Code of Practice: Managing the risks of plant in the workplace</i>



<b>5. Keep records of risk assessment and controls</b>						
The PCBU must make and keep a record of any risk assessment undertaken in relation to the temporary repair, including the controls identified and implemented to eliminate and minimise the risks identified. If the temporary repair results in a change to a registered design (or is such that the mobile plant is required to be registered) there are additional requirements including in relation to record-keeping which are not reflected below.						
Duty holder to whom this obligation applies		Relevant provisions of the WHS Act	Relevant provisions of the WHS Regulations	Relevant provisions of the Mining Regulations	Applicable codes of practice	
a)	PCBU	-	-	cl 9		



**6. Provide information, training, instruction and supervision to workers in relation to the temporary repair**

The PCBU must provide its workers with information, training, instruction or supervision in relation to:

- how the temporary repair is to be carried out;
- the control measures which have been implemented to eliminate and minimise the hazards and risks arising from the implementation of the temporary repair and on an ongoing basis; and
- how the suitability of the temporary repair, and control measures, are to be monitored and risk assessed on an ongoing basis.

A record of any training provided must be kept by the PCBU.

Duty holder to whom this obligation applies		Relevant provisions of the WHS Act	Relevant provisions of the WHS Regulations	Relevant provisions of the Mining Regulations	Applicable codes of practice
a)	PCBU	s 19	cl 39	cl 104 & 108	
b)	Workers	s 28	-	-	



**7. Engage in ongoing review, maintenance and monitoring of the temporary repair and the controls implemented**

After the temporary repair is carried out, and the relevant controls implemented, the PCBU must implement processes for the ongoing review, maintenance and monitoring of the temporary repair to ensure that the controls, and the temporary repair, remain effective and fit for purpose for the life of the temporary repair. This includes ensuring that the repair is capable of being properly inspected. The nature and scale of the temporary repair, and the failure that it is designed to address, will determine the frequency of inspections and monitoring (for example, each shift, daily, weekly or on a hundreds or thousands of hours basis). Where a duty holder apart from the PCBU implements a control measure, they will also need to implement a process for reviewing, maintaining and monitoring the effectiveness of that control.

It may be appropriate to seek advice from a specialist contractor or expert regarding the state of the temporary repair throughout its life cycle.

Where a control is found to be ineffective, or no longer fit for purpose, the temporary repair must be reassessed and further (or amended) controls implemented in line with steps 1 – 4 set out above.

Duty holder to whom this obligation applies		Relevant provisions of the WHS Act	Relevant provisions of the WHS Regulations	Relevant provisions of the Mining Regulations	Applicable codes of practice
a)	PCBU	s 19	cl 37, 38 & 213	cl 10	Safe Work Australia, <i>Model Code of Practice: How to Manage work health and safety risks</i>
b)	Worker	s 28	-	-	
c)	Designer	-	cl 37 & 38	-	SafeWork Australia, <i>Model Code of Practice: Managing the risks of plant in the workplace</i>
d)	Manufacturer	-	cl 37 & 38	-	
e)	Importer	-	cl 37 & 38	-	
f)	Supplier	-	cl 37 & 38	-	
g)	Person who installs, constructs or commissions plant	-	cl 37 & 38	-	



### 8. Establish a process for reporting, verification and assurance

Given the often bespoke design and purpose-built nature of temporary repairs to mobile plant, officers should give special consideration to any temporary repairs when undertaking their broader due diligence activities.

Officers must (among other things):

- take reasonable steps to acquire and keep up to date knowledge of WHS matters;

- gain an understanding of the PCBU's operations and the hazards and risks associated with those operations; and
- verify that the PCBU is complying with its obligations under the WHS Act.

To assist with these obligations in relation to the temporary repair, a process should be established for officers to receive, consider and respond in a timely way to reports on:

- hazards and risks arising from the temporary repair and the operation of the mobile plant;
- the resourcing available to manage those hazards and risks;
- any incidents that occur, and the processes for responding to those incidents; and
- amongst other matters, steps the PCBU has or is taking to consult with, and provide training and instruction to, workers regarding the temporary repair.

Specifically, a process should be established for officers to receive information regarding whether steps 1 – 7, above, are being complied with and that the PCBU has appropriate resources to undertake the process and health and safety activities described at steps 1 – 7, above.

Duty holder to whom this obligation applies		Relevant provisions of the WHS Act	Relevant provisions of the WHS Regulations	Relevant provisions of the Mining Regulations	Applicable codes of practice
a)	Officers	s 27	-	-	(See guidance available regarding "What does an officer need to do?" on the Safe Work Australia website).