

# INVESTIGATION INFORMATION RELEASE

**DATE:** 19 FEBRUARY 2021

## Drift winder head sheave pulley wheel falls from height during winder rope removal

**Incident date:** 6 October 2020

**Event:** Dangerous incident on the surface of underground coal mine

**Location:** Appin East Mine, Appin Colliery, Appin NSW

### Overview

As part of an equipment upgrade project, during the removal of the winder rope from the Appin East drift winder, the head sheave pulley wheel, weighing several tonnes, dislodged from its support frame and fell approximately 13 metres to the ground below. At the time, a contract worker was positioned on the ground level, within a taped off, restricted access area directly below the pulley wheel. The worker had to move in order to avoid being struck by the falling object. No injuries resulted from the incident.

### The mine

The Appin East Mine forms part of the Appin Colliery which is located on Appin Road, Appin about 27 kilometres north-west of Wollongong, NSW. The mine is an underground coal mine that produces coking coal. Endeavour Coal Pty Limited is the mine operator of the Appin Colliery.

### The incident

At the time of the incident, the mine operator had engaged a principal contractor, Winder Controls Australia Pty Limited (WCA), to undertake a drift winder upgrade project. As part of the project, WCA were required to remove the rope from the drift winder. To complete this task, WCA developed and utilised its own rope removal (de-roping) procedure.

In accordance with the procedure, the winder rope was to be fed through the head sheave pulley to a friction winder and then onto a rope reeler (see Figure 1).

Figure 1 Drift winder de-roping procedure

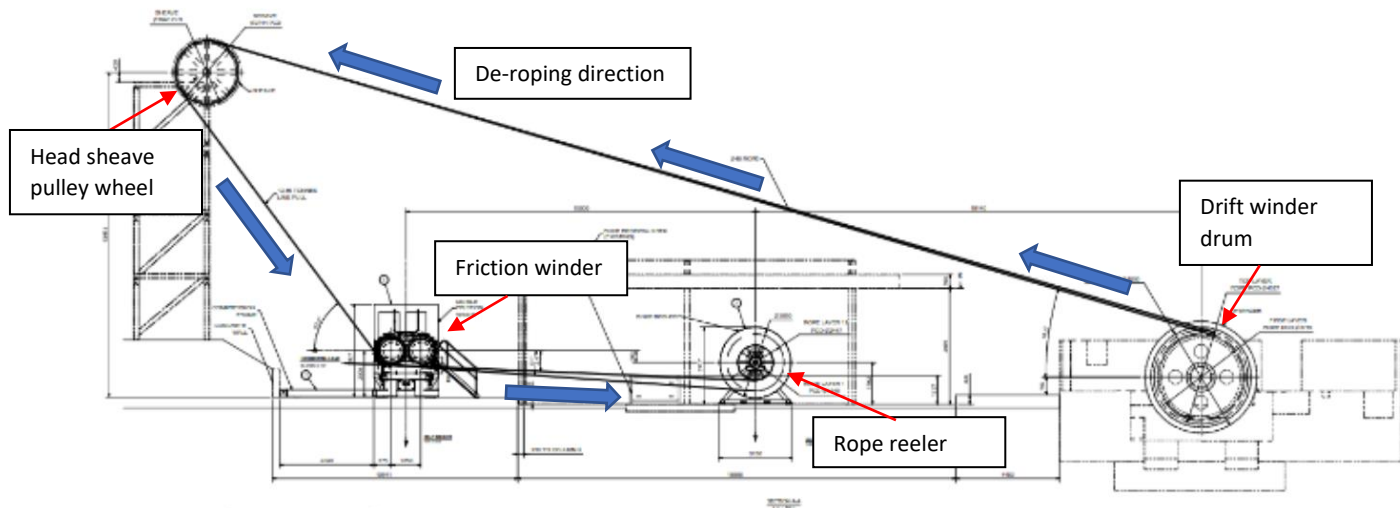

WCA's procedure differed from the process previously utilised by the mine operator, which did not require the use of a friction winder or the rope to be traversed through the head sheave pulley.

During the afternoon on 6 October 2020, WCA prepared to de-rope the drift winder. At around 12:45pm, workers reviewed the procedure and completed a task analysis to identify relevant safety hazards and controls. The analysis identified equipment failure caused by over-tensioning as a hazard. Radio communication, maintaining visual line-of-sight and taping off restricted access areas to keep workers out of the "line-of-fire" were identified as the agreed controls.

At around 4pm, a crew of approximately six workers consisting of WCA workers and subcontractors and a mine worker commenced de-roping the drift winder. The procedure required the work crew to coordinate their operations using UHF radio communications and direct line-of-sight to ensure sufficient tension was maintained on the rope during the process.

Not all work crew members were provided with radios and some encountered difficulties using them due to loud background machinery noise, having to resort to ad-hoc hand signalling methods.

Initial inquiries have indicated that, during the de-roping process, the drift winder stopped winding out rope whilst the friction winder and rope reeler were still operating and winding in rope. This caused tension in the winder rope to increase, introducing significant forces on the head sheave pulley wheel assembly.

At around 4:53pm, nearby workers heard a loud cracking sound and observed the head sheave pulley wheel dislodge from its support frame and fall approximately 13 metres to the ground (see Figure 2).

Examinations conducted after the incident identified that the plumber blocks and associated fastening bolts, which form part of the pulley wheel assembly, were significantly damaged (see Figure 3).

Figure 2 Head sheave pulley wheel location post incident



Figure 3 Damaged head sheave pulley wheel assembly components



Just before the failure, a member of the work crew was standing on ground level directly below the pulley wheel within a taped off, restricted access area (see Figure 4). The worker was monitoring the rope to ensure it was correctly travelling through the friction winder. After hearing the cracking noise, the worker took immediate evasive action, moving clear of the fall path of the pulley wheel moments before it hit the ground.

Figure 4 Final location of pulley wheel within taped off, restricted area near drift winder



The NSW Resources Regulator's initial inquiries have indicated that:

- The friction winder's maximum rope pull force was set above the maximum safe working load limit of the head sheave pulley assembly.
- During the rope removal, significant forces were exerted onto the head sheave pulley wheel assembly which likely damaged the assembly components, resulting in the pulley wheel dislodging from its support frame and falling to the ground.
- Implemented communication protocols had not appropriately considered the work environment, such as loud background machinery noise.
- Restricted access areas were not clearly defined within procedures or adequately implemented through clear instruction and supervision.
- During the rope removal, a worker was positioned below the head sheave pulley wheel, within a restricted access area, under the assumption that approval had been given to do so.

## The investigation

The Regulator has commenced an investigation to determine the cause and circumstances of the incident. The investigation will, among other things, consider the design of the equipment, instruction, training and supervision of the workers involved, as well as the adequacy of policies and procedures relevant to the incident. The mine operator and the contractor are co-operating with the investigation. A report will be published when the investigation is concluded.



## Safety Observations

Mine operators and contractors are reminded of their duty to identify hazards and manage risks to health and safety in accordance with the provisions of the *Work Health and Safety Act 2011* and *Work Health and Safety (Mines and Petroleum Sites) Act 2013* and regulations.

Mine operators should:

- Ensure change management procedures are developed, implemented and routinely followed to appropriately consider the health and safety risks associated with modifying existing work processes.
- Monitor and review contractors' procedures and supervise work practices to ensure implemented safety controls are consistent with the mines safety management system.
- Review drift winder rope removal procedures and risk assessments to ensure that the safe working load limits of the involved plant and equipment are appropriately considered.

Contractors should:

- Ensure drift winder rope removal procedures and risk assessments incorporate appropriate engineering controls to prevent the safe working load limits of involved plant and equipment from being exceeded.
- Provide adequate instruction and supervision to workers to ensure that, when task procedures have changed from those originally planned, adequate new risk control measures are put in place.
- Review communication protocols to ensure that appropriate consideration is given to the work environment, such as loud background machinery noise.
- Ensure procedures clearly articulate no-go zones and restricted access areas with workers provided clear instruction, training and supervision to ensure they are adhered to.

Workers should:

- never enter identified no-go zones in the potential line-of-fire of falling objects caused by equipment failure while energy is being applied to a pulling system.

## Further information

Please refer to the following guidance materials:

- Code of Practice - [Managing the risks of plant in the workplace](#)
- Code of Practice – [Mine shafts and winding systems](#)
- Technical reference guide – [Powered Winding Systems Part 2: Drift winders](#)
- Investigation information release - [IIR16-06 Fatality from falling object](#)
- Safety Alert - [SA09-14 – Crane A Frame mast falls on rigger](#)

## About this information release

The Regulator has issued this information to draw attention to the occurrence of a serious incident in the mining industry. Further information may be published as it becomes available.

Visit our [website](#) to:

- learn more about our work on causal investigations and emergency response
- view our publications on other causal investigations.

© State of New South Wales through Regional NSW 2021. You may copy, distribute, display, download and otherwise freely deal with this publication for any purpose, provided that you attribute Regional NSW as the owner. However, you must obtain permission if you wish to charge others for access to the publication (other than at cost); include the publication in advertising or a product for sale; modify the publication; or republish the publication on a website. You may freely link to the publication on a departmental website.

Disclaimer: The information contained in this publication is based on knowledge and understanding at the time of writing (February 2021) and may not be accurate, current or complete. The State of New South Wales (including Regional NSW), the author and the publisher take no responsibility, and will accept no liability, for the accuracy, currency, reliability or correctness of any information included in the document (including material provided by third parties). Readers should make their own inquiries and rely on their own advice when making decisions related to material contained in this publication.

### DOCUMENT CONTROL

<b>CM9 reference</b>	DOC21/91906
<b>Mine safety reference</b>	IIR21-02
<b>Date published</b>	19 February 2021
<b>Authorised by</b>	Chief Investigator, Major Safety Investigations