

Wabtec Generation 3 CAS Product Overview

NSW Resources Regulator/NSW Minerals
Council Collision Avoidance forum

22 Feb 2023

The information contained in this document may contain confidential, proprietary and/or privileged material of either Wabtec Corporation or one of its subsidiaries. Any review, retransmission, dissemination or other use of, or taking of any action in reliance upon, this information by persons or entities other than the intended recipient is prohibited unless authorized in writing. If you have received this document in error, please contact the sender and delete the material from any system and destroy any copies.





Corporate headquarters
PITTSBURGH, PA

27K
EMPLOYEES

50
COUNTRIES

\$ 8B
REVENUE

FORTUNE
500
COMPANY

Equipment

23,000+

Locomotives in installed base

Components

100+

Countries with Wabtec products on locomotives and freight cars

Experience

125+

Years of mining experience

Monitoring

7,000+

Fixed and Mobile assets being monitored

Services

17,000+

Locomotives monitored globally
+2.5 million data points analyzed

Signaling

20,000+

Locomotives equipped with PTC computers/software

Collision Avoidance

12,000+

Vehicles fitted with CAS

Electric Wheel Drives

15,000+

Wabtec Electric Drives on Haul Trucks



Freight

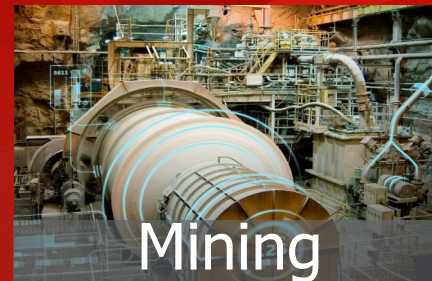

Mining



Why Collision Avoidance (CAS)?

“Each year, between 30-40% of industry deaths are attributable to failures of vehicle interaction controls”

EMESRT, 2023

“We aspire to Zero Harm to people, our host communities and the environment...”

BHP Mission Statement, 2023

At Wabtec, we support mining customers to implement zero harm objectives, augmenting existing mine site controls with our leading CAS technology to significantly reduce risk

CAS – Wabtec Generation 3

- Next Generation Wabtec Collision Awareness & Avoidance System
- Developed in partnership with Glencore Coal Australia to Industry Functional Performance Requirements
- Game Changing Performance & User Experience > accelerate 'zero harm' objectives
- Complies with Industry Best Practice (EMESRT/ICMM) > levels 7 (operator awareness), level 8 (advisory controls) and level 9 (intervention controls), including:
 - EMESRT Baseline VI scenarios
 - EMESRT Discrete Scenarios (Storyboards)
- High accuracy sensing > close interactions w/o over-alarming during normal operations, improved operator acceptance
- Low temperature support > operation down to -40 deg C

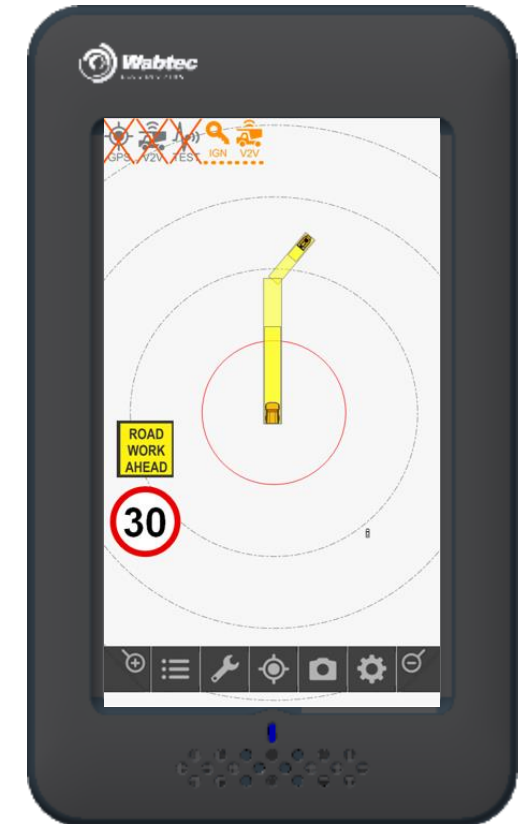

CAS – Wabtec Generation 3

- Smarter 'rules & intelligence' engine > alarms by exception when deviating from mine site procedures, CAS supports production
- Curved detection beams follow vehicle heading > accurate discrimination between 'safe-interaction' versus 'dangerous interaction' eliminates nuisance alarms and production impact at L8 / L9
- Improved User Interface based on best-practice Human Factors Engineering > improved operator acceptance
- Voice based warnings > provides specific context of threat and expected response, reduces operator reaction time and distraction viewing screen

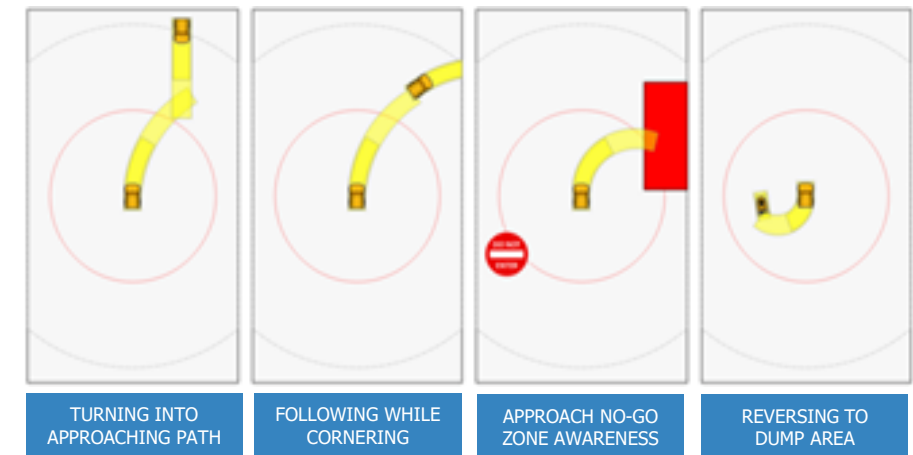
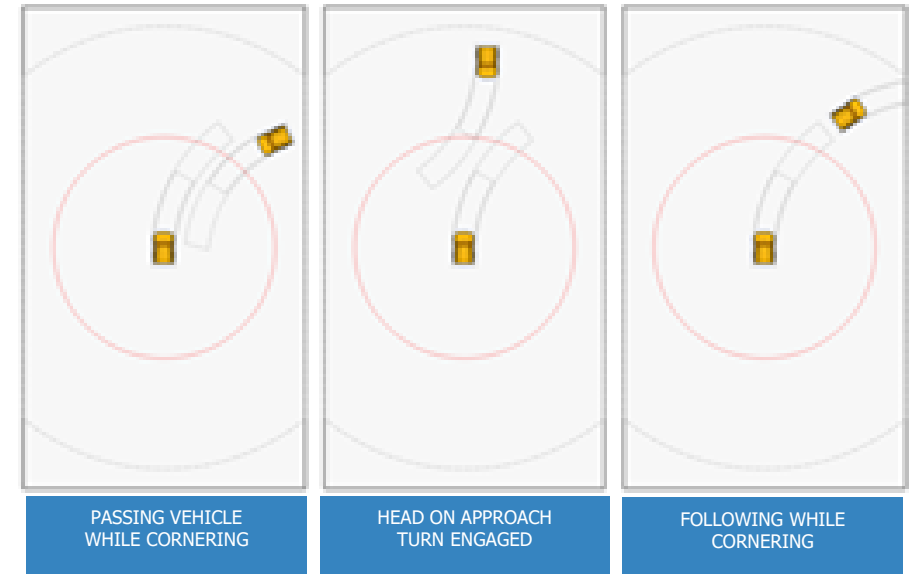

Industry Alignment

Supports EMESRT Baseline Vehicle Interaction Scenarios At All Speeds

LEGEND

EMERST PR5A SOLUTION

- 7 LEVEL 7 - Operator Awareness
- 8 LEVEL 8 - Advisory Controls
- 9 LEVEL 9 - Intervention Controls

STATUS

- AVAILABLE NOW
- FUTURE

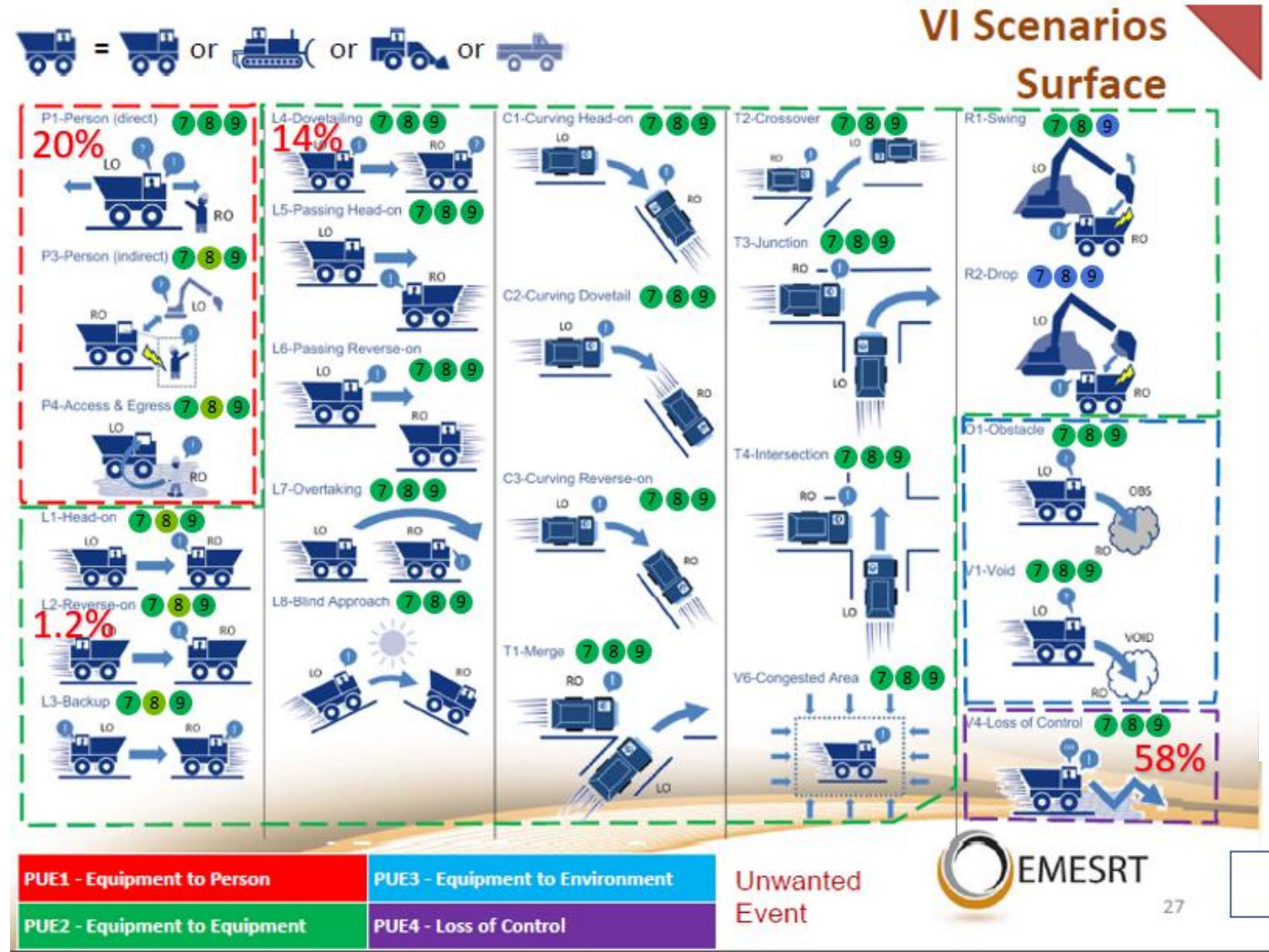

Industry Alignment

Supports EMESRT Discrete Scenarios (Storyboards)

Tailgating

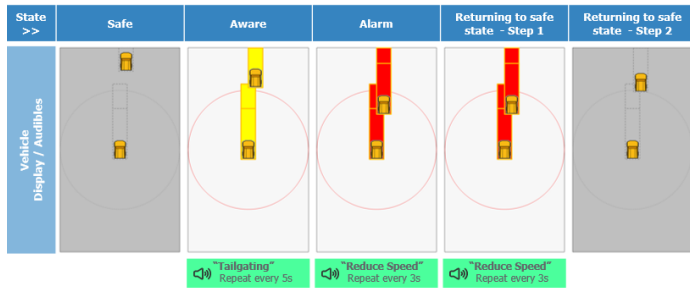

Speeding

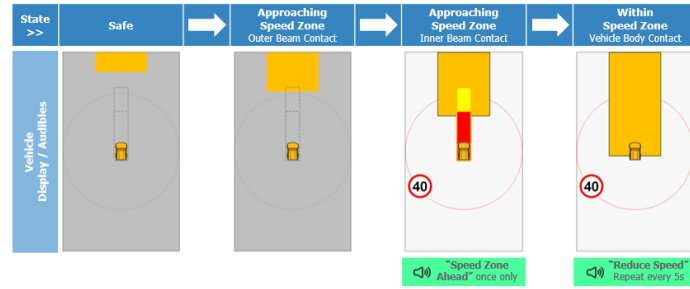

Wet Roads

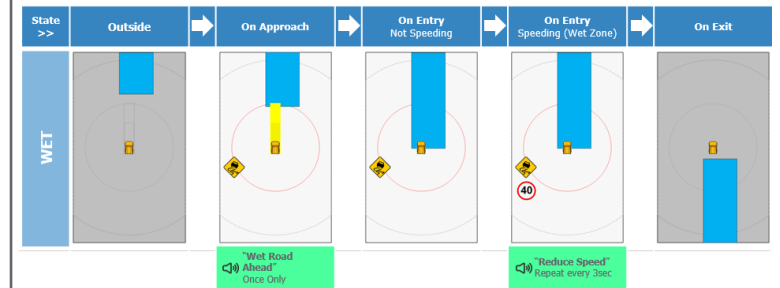

T-intersections

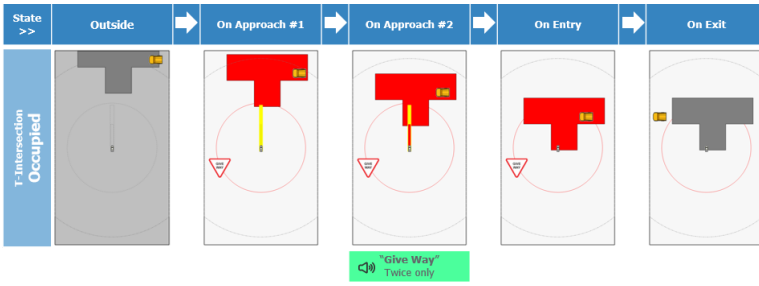

Dump Areas

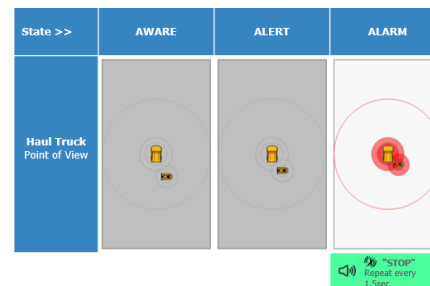

Load Areas

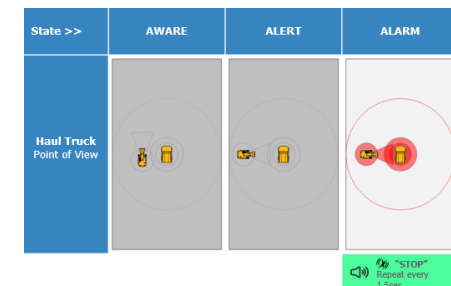

Passing & Accessing HV's (with digital handshake)

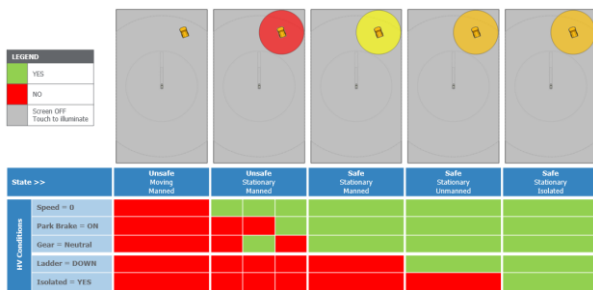

Segregated Roads

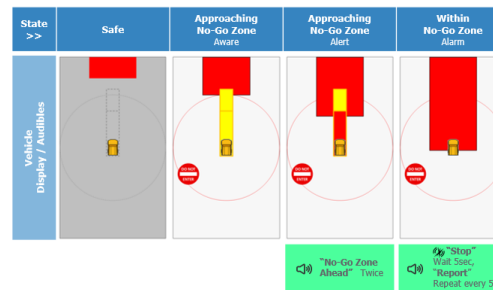

Passing Road Works Vehicles



Escalating Unsafe Situation

3 Levels of Warning: Example 2 x Haul Trucks travelling at 30km/h

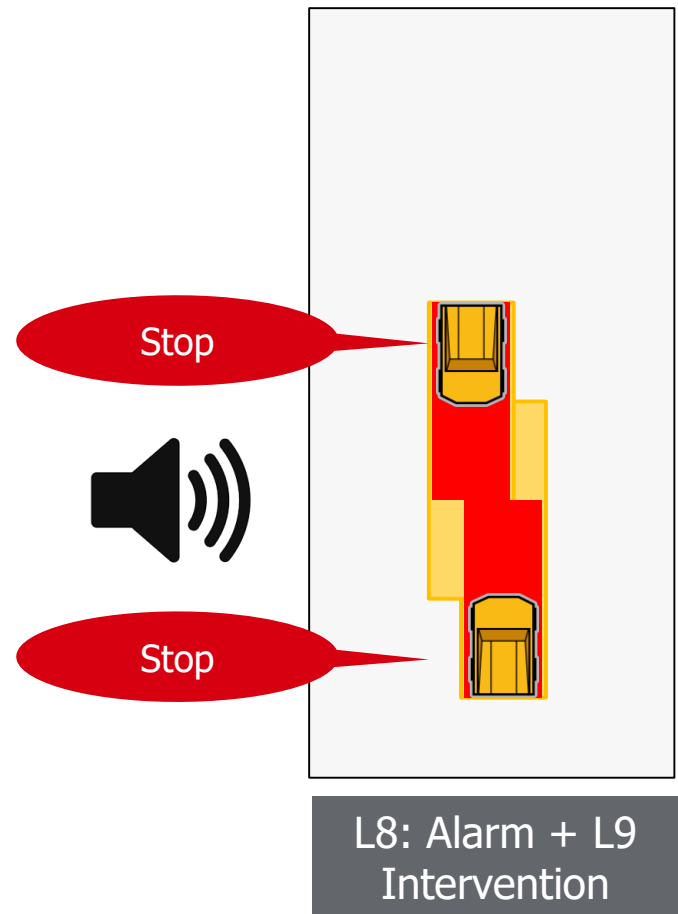
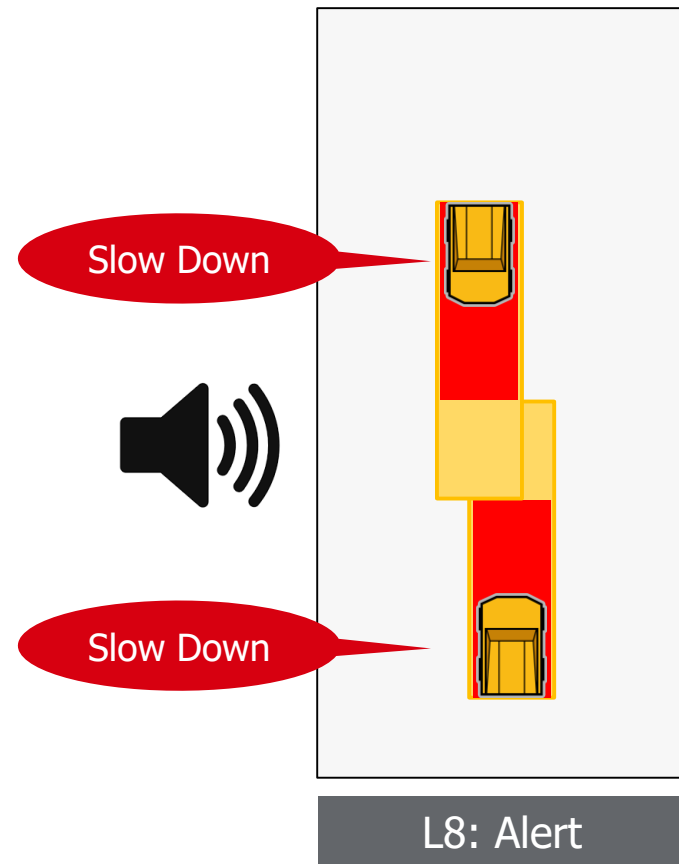
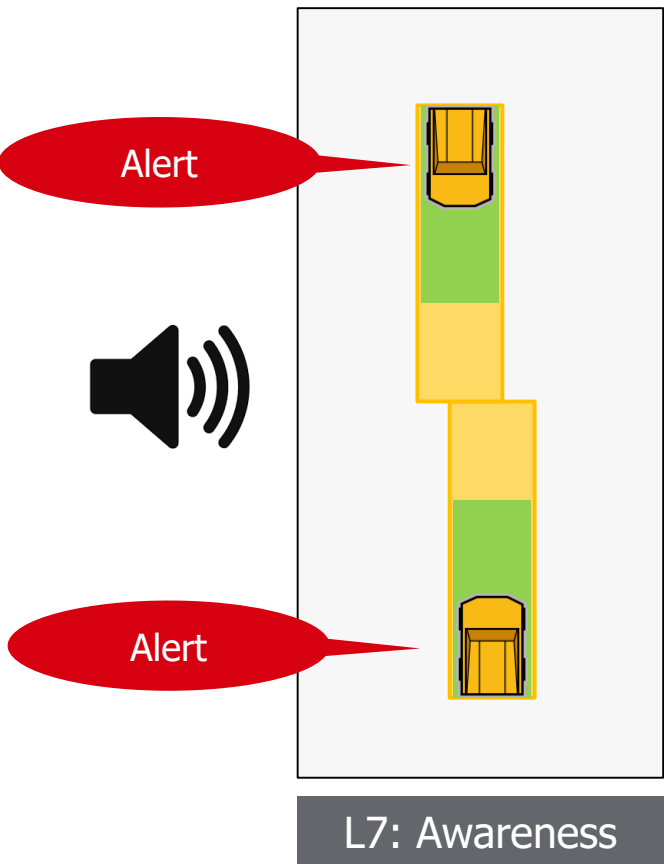

Escalating warning to the vehicle operator of proximity to a remote vehicle

Wabtec's CAS Gen 3 is designed to ONLY alarm when a high risk incident is likely.

This greatly reduces operator alarm fatigue and minimises the risks associated with nuisance alarming i.e complacency.

Level 9 Intervention Controls

- Level 9 'L9' intervention is an extension of a high performing L7/8 system. This ensures **minimal production impact** and **reduced vehicle wear and tear** as the system responds to excessive interaction alarms
- Support for **intervention across all speed ranges**, including take-off inhibit, controlled slow down, speed governing, stop
- Wide range of scenarios, supporting configurable detection zones and stop gaps incorporating machine parameters to tune intervention performance
- **Proven integration with leading OEMs**, with initial validation at OEM "proving grounds" and then proven on customer sites

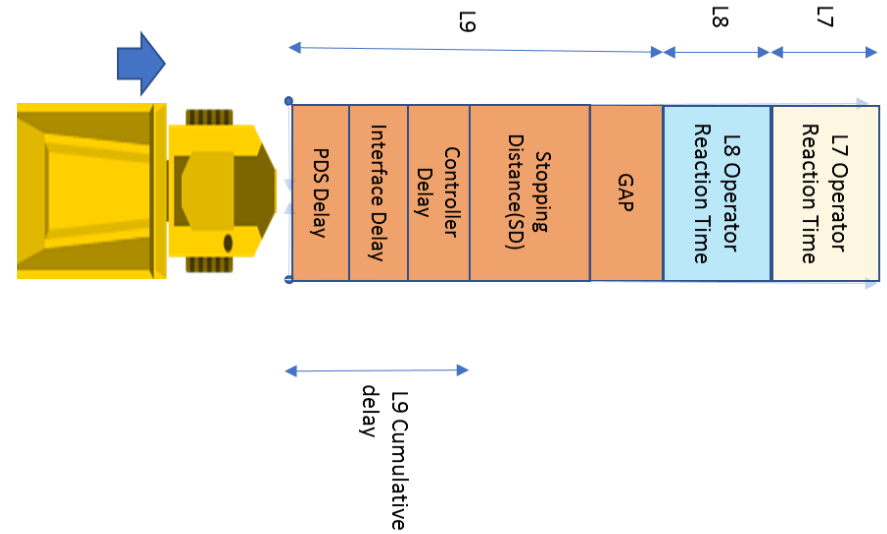
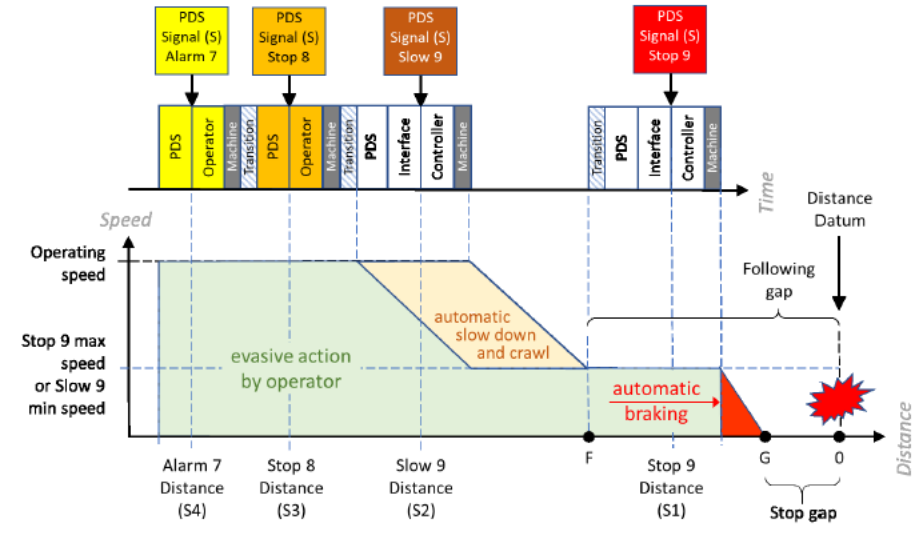

Head On Scenario @ 20kph – External View



- The vehicles approach each other at predefined speeds (in this case 20kph)
- The vehicles are expected to automatically stop before the configurable stop gap (in this case 20m)

The distance left when both vehicles are motion inhibited

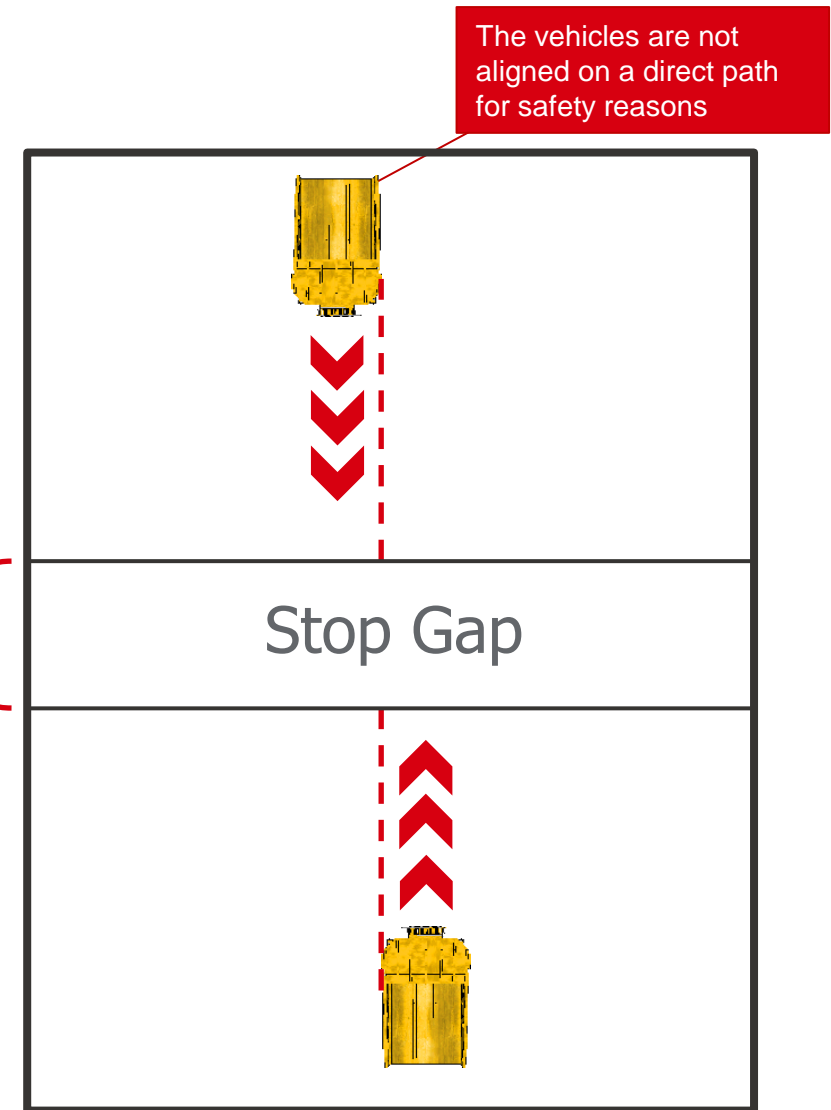

Generation 3 CAS - Operator Interface

Fault Icons

Warning Icons

Special Icons
Multiple icons display vertically.

Features Menu
Tap Screen to display.

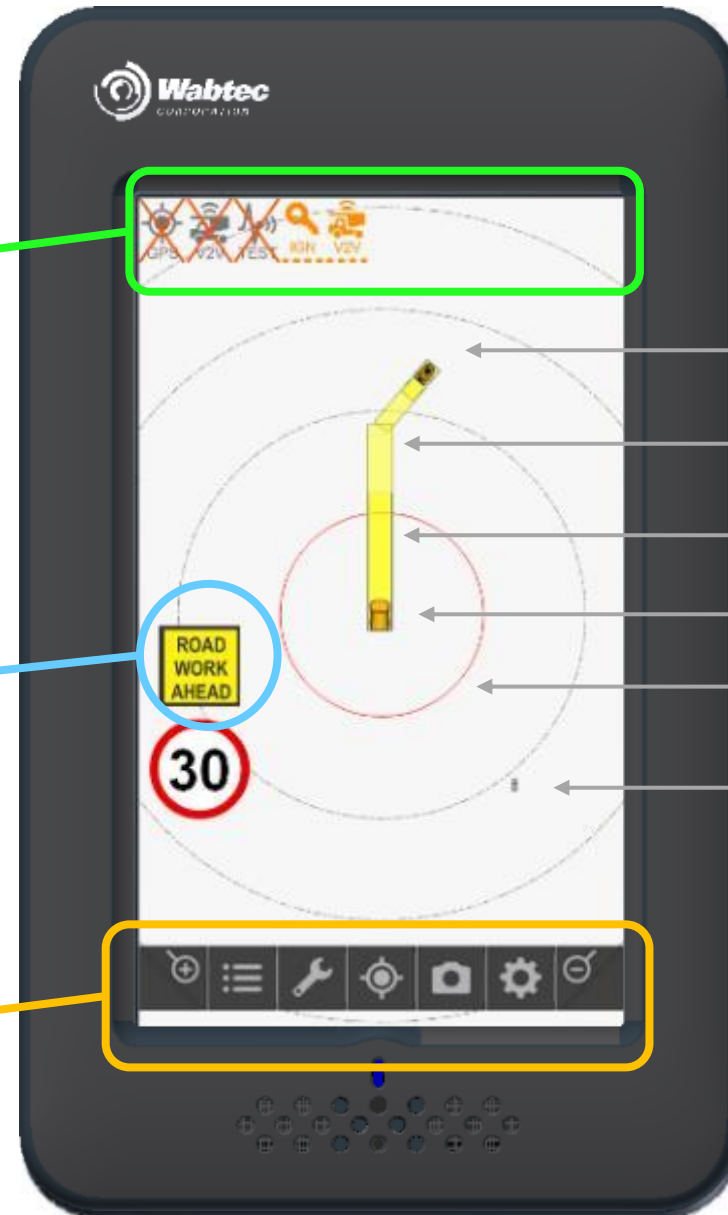

Dozer (RO)

Outer-Beam (LO)

Inner-Beam (LO)

Haul Truck (LO)

50m radius from LO

Light Vehicle (RO)

Monitoring CAS Health

- With intervention taking place, it's more important than ever to ensure the system operates correctly
- Real-time system health monitoring & reporting of critical CAS safety functions (GNSS, V2V, ToF RF and more)
- Allows fail to safe operation – operators will be notified as soon as critical failures are identified
- Event logged in CAS Web – for maintenance personnel to support quick Go/No-Go decision for operation



CAS Operation

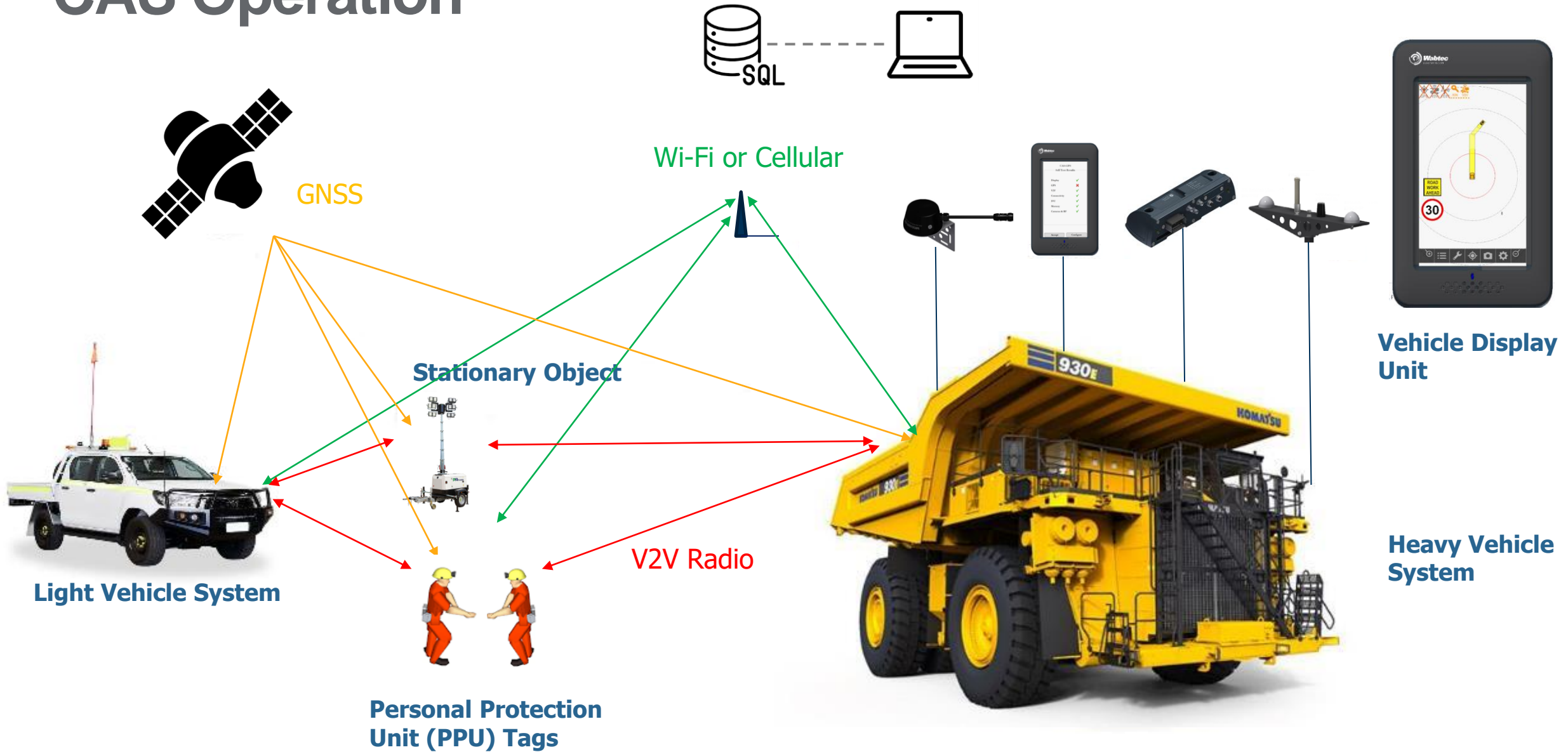

Key Hardware Components of CAS - HV



Key Hardware Components of CAS – LV (fixed system)



Display

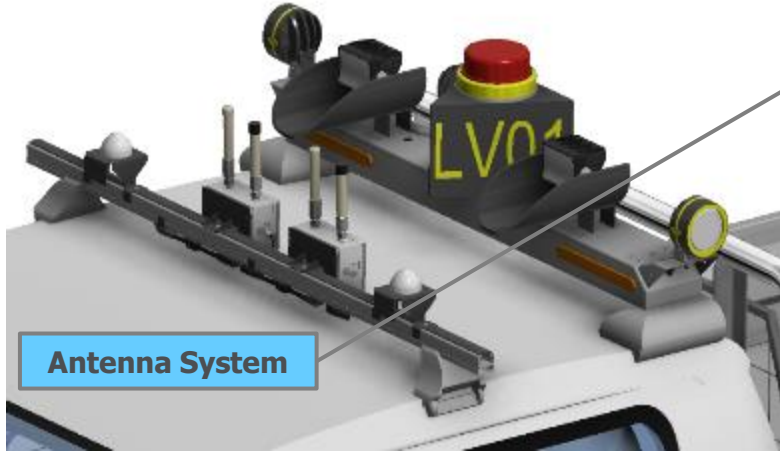

Antenna System

Key Hardware Components of CAS – LV (portable)

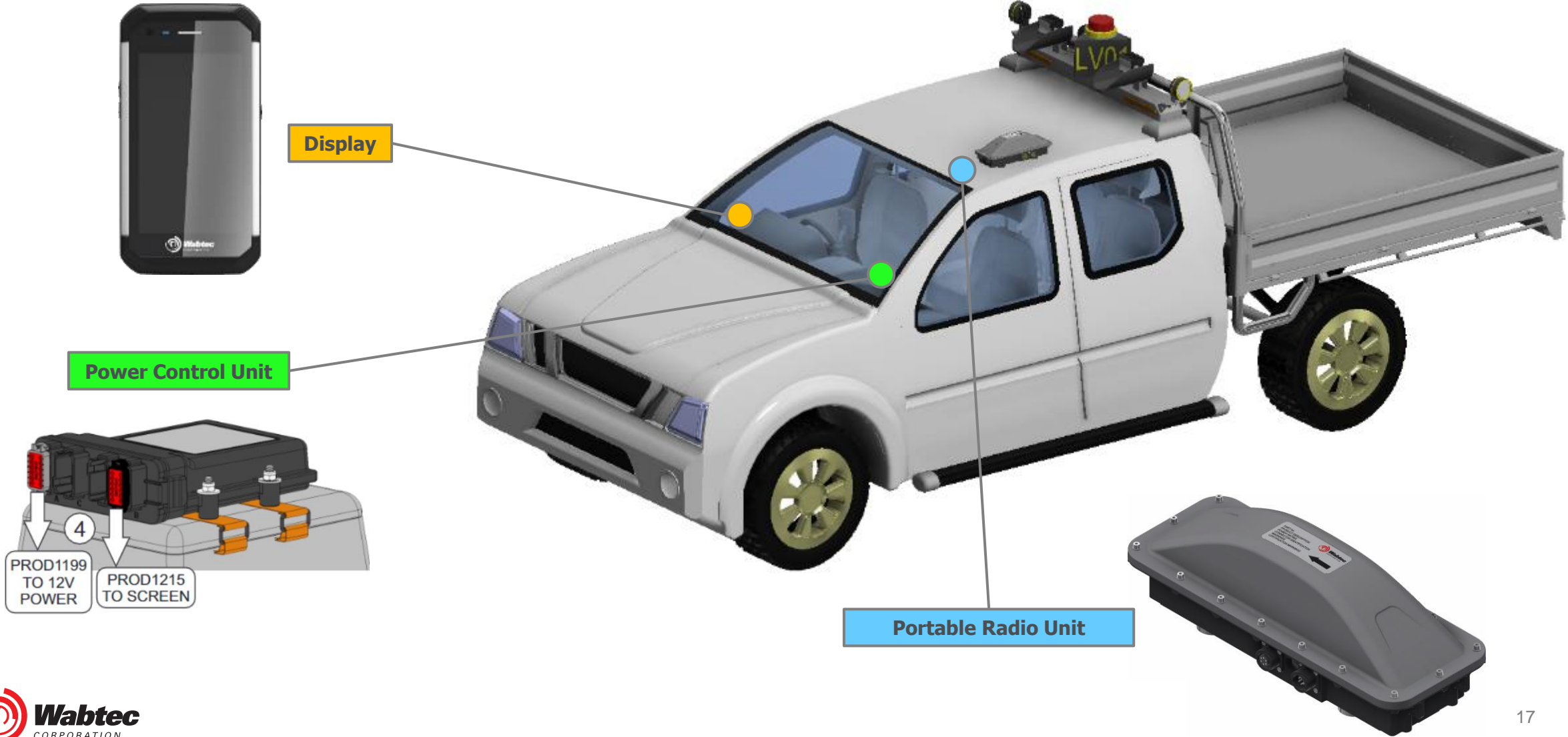

Optimising CAS Performance

- Wabtec's CAS includes CAS Web – a web-based application providing analysis and reporting to help you better understand vehicle movements and interactions
- The server can be customer hosted ('on-premise') or hosted by Wabtec in the cloud
- Capabilities include:
 - Mine interaction hotspots
 - Live vehicle position information
 - Historical journey replays for incident analysis
 - Rich geofence management capabilities for scenario management across vehicle types
 - Reports on demand or by schedule
- CAS Downloader allows over the air CAS software and configuration updates to ensure optimal operation

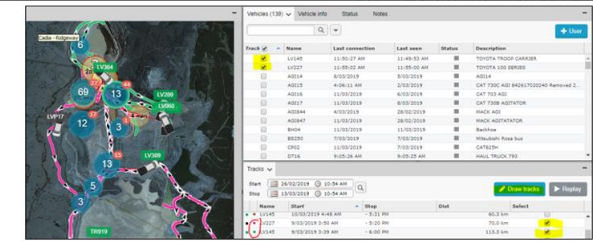
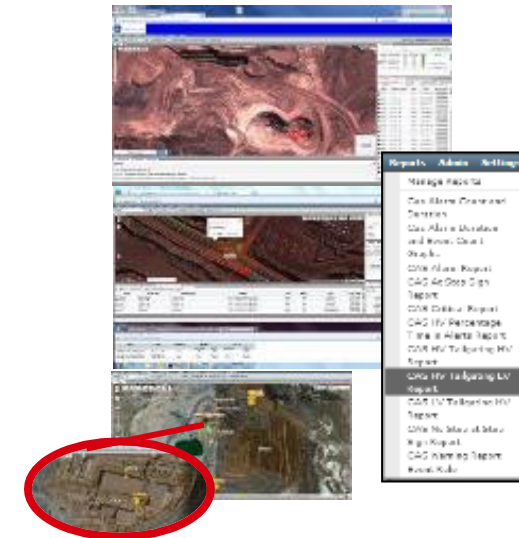

Technology Limitations

Key Challenges & Expectations

- **CAS is NOT a 'silver bullet'** to managing VI risk – mine site controls L1-L7 are most effective when mature and implemented effectively
- **L8/L9 is NOT a standalone product** but based on high integrity L7 platform – L9 is a machine control performance level (by scenario, machine make/model & mine site operations)
- **L8 performance is a pre-cursor to L9** otherwise production maybe impacted by nuisance alarms

Evolution of Wabtec CAS

Key Themes

- Enhanced 'Rules & Intelligence' supporting more complex scenario-based interaction scenarios
- Cloud as platform for enhanced reporting / management capabilities
- Integration with other operational technologies
- AHS + CAS co-existence
- + a lot more

Thank you!

accelerating the future

of mining



Wabtec
CORPORATION