



Department
of Industry
Resources & Energy

Mine Safety

MINING DESIGN GUIDELINE | MDG 42.1

Person-riding hoists (winding systems) in small gemstone mines

Part 1: Design



Published by NSW Department of Industry, Skills and Regional Development

MDG 42.1 Person-riding hoists (winding systems) in small gemstone mines Part 1: Design

First published October 2015

More information

NSW Mine Safety

www.resourcesandenergy.nsw.gov.au/safety

PUB15/444

© State of New South Wales through the NSW Department of Industry, Skills and Regional Development 2015

This publication is copyright. You may download, display, print and reproduce this material in an unaltered form only (retaining this notice) for your personal use or for non-commercial use within your organisation. To copy, adapt, publish, distribute or commercialise any of this publication you will need to seek permission from the NSW Department of Industry, Skills and Regional Development.

Disclaimer: The information contained in this publication is based on knowledge and understanding at the time of writing (October 2015). However, because of advances in knowledge, users are reminded of the need to ensure that information upon which they rely is up to date and to check currency of the information with the appropriate officer of the NSW Department of Industry, Skills and Regional Development or the user's independent advisor.

Foreword

In recent years there has been an increase in the number of injuries involving person-riding hoists (winding systems) in small gemstone mines.

MDG 42 is divided into two parts:

- Part 1 provides guidance on the design of person-riding hoists (winding systems) in small gemstone mines.
- Part 2 provides guidance on the maintenance of person-riding hoists (winding systems) in small gemstone mines.

At the time of publication, section 2 of MDG 42.1 has legal effect in accordance with the *Registration of Person-Riding Hoists (Winding Systems) in Small Gemstone Mines Design Order 2015* and is published for the purpose of plant design registration for person-riding hoists (winding systems) in small gemstone mines under clause 177 of the *Work Health and Safety (Mines) Regulation 2014* and Part 5.3 of the *Work Health and Safety Regulation 2011*, refer Appedix E

This guideline provides an industry benchmark for designing person-riding hoists (winding systems) in small gemstone mines. It represents acceptable industry practice for reducing the risks associated with the use of this equipment.

The principles contained in this document are intended as information to assist industry to devise safety standards. Designers, manufacturers, owners and users of person-riding hoists (winding systems) for small gemstone mines should rely on their own advice, skills and experience in applying risk and safety management systems in individual workplaces.

MDG 42.1 was originally distributed to industry, the Lightning Ridge Miners Association and Glengarry Grawin Sheeppyard Miners Association for consultation.

A feedback sheet is provided at Appendix E. Constructive comment is essential to help the department improve these industry guidelines.

Contents

1	Purpose and scope	1
1.1	Purpose	1
1.2	The purpose of this guideline is to minimise risks to the health and safety associated with the use of design of person-riding hoists (winding systems) in small gemstone mines.	1
1.3	Application	1
1.4	Definitions and abbreviations	1
1.4.1	Definitions	1
1.4.2	Abbreviations	2
2	Design registration requirements.....	3
2.1	General.....	3
2.2	The winch	3
2.2.1	General.....	3
2.2.2	Brakes	3
2.2.3	Ropes	3
2.3	Sheave	4
2.4	Cage/platform	4
2.5	Control.....	4
2.6	Headframe and shaft guides	4
2.7	Testing for registration	5
2.8	Documents.....	5
3	Hoist design risk management	6
3.1	General duties in relation plant.....	6
3.1.1	Design, manufacture, import, supply	6
3.1.2	Calculation, analysis, testing or examination.....	6
3.1.3	Information to be provided	7
3.1.4	Maintenance of control measures	7
3.2	Risk management	7
3.3	Hoisting hazards	8
3.4	Assessing risks	9
3.5	Controlling risks	10
3.5.1	Other risk controls.....	11
3.6	Safe systems of work and operator competencies	11
3.7	Information.....	11
4	Appendices	12
4.1	Appendix A: Reference documents	13
4.2	Appendix B: Typical hoisting hazards, risks and controls	14
4.3	Appendix C: Good practice for design of person-riding hoists	18

4.3.1	General.....	18
4.3.2	The person-riding hoist winch	18
4.3.3	Ropes	20
4.3.4	Sheave wheels	21
4.3.5	Cage/platform	21
4.3.6	Controls	22
4.3.7	Head frame/shaft guides.....	22
4.3.8	Landings	23
4.3.9	Electrically operated hoists	23
4.4	Appendix D: Common plant hazards.....	25
4.5	Appendix E – <i>Registration of Person-Riding Hoists (Winding Systems) in Small Gemstone Mines Design Order 2015</i>	27

1 Purpose and scope

1.1 Purpose

1.2 The purpose of this guideline is to minimise risks to the health and safety associated with the use of design of person-riding hoists (winding systems) in small gemstone mines.

This guideline sets out design requirements in section 2 for the design, testing and performance of person-riding hoists (winding systems) for use in small gemstone mines.

Compliance with this standard does not negate the designer's work health and safety duties under section 22 of the *Work Health and Safety Act 2011*.

This guideline:

- a) provides guidance in design risk assessments (identifying potential hazards, assessing risk and implementing appropriate risk controls), refer to Section 3
- b) specifies minimum design requirements, refer to Section 2
- c) provides a summary of good engineering practice to be considered, see Appendix C.

1.3 Application

Section 2 of this guideline is applicable to the design of all person-riding hoists (winding systems) in small gemstone mines, intended to be design registered under clause 177(5) of the *Work Health and Safety (Mines) Regulation 2014* and Part 5.3 of the *Work Health and Safety Regulation 2011*.

Note: Appendix A provides information on reference documents and definitions used in this guideline.

1.4 Definitions and abbreviations

1.4.1 Definitions

In this guideline, the following definitions apply:

Competent person means a person who has acquired, through training, qualification or experience, the knowledge and skills to carry out the task.

Conveyance means a conveyance that is connected to a winding system, and includes any cage, platform or carriage in which people or material are wound through the shaft.

Dead load means the mass of the conveyance and the permanent attached components.

End of rope load means the sum of the dead load and the rated load.

Factor of safety means the ratio of the breaking strength to the rated load being applied. For ropes, this means the ratio of the manufacturers' designed rope break strength to the maximum rope load.

Life cycle includes design, manufacture, construction or installation, commissioning, operation, maintenance, repair, decommissioning and disposal.

Must indicates that legal requirements exist and must be complied with.

Operator means the person that uses the person-riding hoists.

Person-riding hoists means a winding system used in an underground mine, that is a small gemstone mine, where the winding system lifts no more than 40 metres from the surface of the small gemstone mine to the underground workings and carries no more than two people.

Rated load means the maximum load a conveyance is design to carry during normal use.

Should indicates a recommended course of action.

Small gemstone mine means a gemstone mine (including an opal mine) that has less than five workers, as defined in clause 3 of the *Work Health and Safety (Mines) Regulation 2014*.

Winding system means any plant (other than a portable winch or plant that is manually operated) that is used in a shaft to lift a person to or from an underground mine or between levels in an underground mine (regardless of whether it is used exclusively for that purpose).

1.4.2 Abbreviations

AS	Australian Standard
AS/NZS	Australian/New Zealand Standard
MDG	Mining Design Guideline produced by the NSW government and published on the NSW Department of Industry website
PCBU	Person Conducting a Business or Undertaking
WHS Act	<i>Work Health and Safety Act 2011</i>
WHS Regulation	<i>Work Health and Safety Regulation 2011</i>

2 Design registration requirements

All newly designed person-riding hoists must comply with the following design requirements.

Appendix C provides good practice that should be considered when designing person-riding hoists (winding systems) for use in small gemstone mines. A risk management approach must be taken to decide whether guidance in Appendix C is followed.

2.1 General

Each person-riding hoist must be designed by a competent person(s).

The design of the person-riding hoist must:

- a) not carry more than two people
- b) be based on a weight of 120 kilograms per person and this weight must be used for all calculations and testing
- c) ensure that all moving components of the drum drive system are adequately guarded, e.g. sprockets, chains, rope drums, gears and sheaves
- d) ensure that all moving parts requiring lubrication are able to be effectively lubricated
- e) (including the shaft) be securely fenced to stop anyone inadvertently falling down the shaft.

2.2 The winch

2.2.1 General

- a) The drive must be capable of lifting and lowering the end of rope load. All drive components must be rated for this load.
- b) All driving mechanisms used between the drive drum and the device that holds the winch stationary (i.e. brakes or appropriate worm type gearbox that exhibits properties of static and total dynamic irreversibility) must be positive type driving mechanisms.

Note: Clutches, vee belts or fluid couplings are not positive type driving mechanisms and they must not be used between the drive drum and braking device. However, they may be used between the drive motor and the means to hold the winch stationary (i.e. brake) provided the winch remains stationary when the drive motor is stopped or if failure of power transmission was to occur.

The operating speed must be sufficiently slow to allow an operator to recognise and avoid a potential hazard by stopping the winch in time to avoid the potential danger.

- c) The drive system must not be capable of breaking the rope under any condition.

2.2.2 Brakes

- a) The person-riding hoist must have the means to bring the conveyance to rest and hold it stationary. The means must be based on a fail-to-safety principle, i.e. spring applied or gravity applied. Where a worm-type gearbox is used, it must exhibit properties of static and total dynamic irreversibility throughout its lifecycle.

Note:

Dynamic irreversibility occurs when the output shaft of the worm type gearbox stops as soon as the driving force applied to the input shaft is stopped.

Static irreversibility occurs when the output shaft of a worm type gearbox remains stationary after the application of a load.

- b) The stopping or holding means must be capable of holding two times the end of rope load stationary when stopped.

2.2.3 Ropes

- a) Person-riding hoist ropes must have a minimum factor of safety of 10:1 when newly installed.
- b) A used rope must not be reinstalled unless it can be proven to be safe to use.

- c) A spliced connection must not be used to join two or more ropes together.

2.3 Sheave

- a) All sheaves must be rated for the load to be lifted and the power developed by the winch.
- b) A method of retention to prevent the rope from leaving the sheave groove must be provided.

2.4 Cage/platform

- a) Each cage/platform must be designed for the application and load conditions.
- b) Each cage/platform design must have a suitable means to prevent a person(s) from falling out of the cage and prevent entanglement between the cage and shaft while the person(s) is being transported.
- c) An 'emergency arresting device' must be fitted to the cage/platform so that in the event of a rope failure, the cage/platform with its maximum rated load will be automatically brought to rest safely.
- d) A 'manually activated emergency arresting device' must be fitted to the cage/platform so that in the event of winch holding failure, the cage/platform with its maximum rated load may be brought to rest through manual deployment of this device.
- e) The manually activated emergency arresting device may be manual activation of the automatic emergency arresting device.
- f) The cage/platform must have suitable means to prevent the cage/platform from moving away from the shaft guide (ladder).
- g) The spacing of guide devices that connect the cage/platform to the guide rails must be of a suitable distance to ensure stability of the cage/platform at all loads and speeds.

2.5 Control

- a) The person-riding hoist must be able to be controlled from the cage/platform while a person is riding on it.
- b) The person-riding hoist must incorporate an automatic means of stopping the cage/platform at both the top and bottom of the shaft.
- c) A risk assessment that assesses the control circuit failure modes must be carried out on all control circuits, refer to Section 3.
- d) Palm or hand-operated mechanically latched emergency stop switches must be provided and be accessible from within the cage/platform; be accessible to a person at the shaft entrance (near the person-riding hoist motor) and any other location identified in the design risk assessment.
- e) The person-riding hoist must not be able to be started until the emergency stop switch that stopped the person-riding hoist is released.

2.6 Headframe and shaft guides

- a) The head frame must be designed for the application and the load conditions.
- b) The head frame must be securely anchored to prevent dangerous movement, such as overturning or slipping into the shaft.
- c) The shaft guides must be designed to withstand and control the forces applied from a loaded cage/platform moving as it operates up and down in the shaft.
- d) Guide joints must be designed to minimise the potential for jamming of the cage/platform during operation.
- e) Shaft guides must be designed to hold the full load under dynamic conditions with the application of the emergency arresting device at any point in the shaft.

2.7 Testing for registration

- a) The person-riding hoist must be tested to ensure it can raise and lower safely.
- b) The person-riding hoist, including the winch, sheaves, head frame, cage, rope and attachments, must be statically tested to two times the maximum rope load.
- c) The cage/platform emergency arresting system must be dynamically tested for correct operation at the rated payload.
- d) All controls must be tested for correct operation.
- e) The brakes or holding means must be statically tested to two times the maximum rope load.
- f) The brakes or holding means must be dynamically tested at the rated static load. The cage must come to a stop within 0.3 metres of activation of any emergency stop device.
- g) A competent person who was not involved in the production of the design must witness all tests and verify in writing that the above tests have been carried out satisfactorily and the person-riding hoist complies.

Note: It is recommended that a mechanical or electrical inspector from NSW Department of Industry also witness the testing process.

2.8 Documents

Design documents must be kept on file by the designer.

The owner of the person-riding hoist must be provided with sufficient information to allow the person-riding hoist to be operated and maintained in a safe condition for use. This information must include, but is not limited to the following:

- a) All information nominated under 'Information' in Section 3 (see page 15).
- b) A photo of the person-riding hoist.
- c) A drawing or sketch of the person-riding hoist showing and identifying all components of the winch.
- d) A block diagram showing the location of all electrical/hydraulic/pneumatic components on the person-riding hoist.
- e) A winch manufacturer's certificate with rated load and speed.
- f) A commissioning report with all test results listed by a competent person.
- g) Control circuit schematics and a full wiring diagram including: electric, hydraulic and pneumatic, as applicable. These must clearly show the safety circuit and hoist control circuit.
- h) A commissioning report detailing all test results.
- i) A copy of the rope manufacturing certificate applicable to the installed rope. The certificate must include rope construction, wire grade and tensile strength information.
- j) All relevant user information including the following:
 - o any known residual risks and risk control measures provided
 - o the purpose of the person-riding hoist
 - o specific conditions applying to the use of the person-riding hoist
 - o testing, inspections and maintenance to be carried out on the person-riding hoist
 - o safe operating instructions for the person-riding hoist
 - o systems of work for the safe use of the person-riding hoist
 - o emergency procedures.
- k) A type commissioning report detailing all test results and verification of design performance.

3 Hoist design risk management

3.1 General duties in relation plant

A PCBU has a primary duty under section 19 of the WHS Act to ensure, so far as is reasonably practicable, that workers and other people are not exposed to health and safety risks arising from the business or undertaking. This duty includes ensuring, so far as is reasonably practicable, but is not limited to:

- the provision and maintenance of safe plant and structures
- the provision and maintenance of safe systems of work
- the safe use, handling and storage of plant, structures and substances
- the provision of any information, training, instruction and supervision that is necessary to protect all people from risks to their health and safety arising from work carried out as part of the conduct of the business or undertaking.

In meeting this duty at a mine, a PCBU must manage risks to health and safety associated with mining operations at the mine in accordance with Part 3.1 of the WHS Regulation and clause 9 of the *Work Health and Safety (Mines) Regulation 2014*, including but not limited to:

- ensuring that a risk assessment is conducted by a person who is competent to conduct the particular risk assessment having regard to the nature of the hazard
- identifying all reasonably foreseeable hazards
- eliminate risks to health and safety so far as is reasonably practicable
- if it is not reasonably practicable to eliminate risks to health and safety – minimised those risks so far as reasonably practicable in accordance with the hierarchy of risk control measures at Figure 1 below.

Figure 1 - Hierarchy of risk controls

Eliminating	Best
<ul style="list-style-type: none"> • Substituting • Isolating • implementing engineering controls 	Effectiveness does not depend on human behaviour
Administrative controls	Effectiveness depends on human behaviour
Using Personal Protective Controls (PPE)	Does not control the risks directly. It controls the possible harm to a person

3.1.1 Design, manufacture, import, supply

Designers, manufacturers, importers and suppliers of plant, substances and structures have duties under sections 22-25 of the WHS Act. In relation to plant, substances and structures, these duties may be summarised as a duty to ensure, so far as is reasonably practicable, that the plant, substance or structure is without risks to the health and safety of people at a workplace who use the plant, substance or structure for a purpose for which it was designed or manufactured.

3.1.2 Calculation, analysis, testing or examination

Designers, manufacturers, importers and suppliers must also carry out, or arrange the carrying out of, any calculations, analysis, testing or examination that may be necessary for the

performance of the duty imposed by sections 22-25 of the WHS Act, or alternatively, in the case of importers and suppliers, ensure that such calculations, analysis, testing or examination have been carried out.

3.1.3 Information to be provided

Designers, manufacturers, importers and suppliers must also give adequate information to each person to whom they provide the design, plant or structure (and subsequently upon request) concerning:

- each purpose for which the plant, substance or structure was designed or manufactured
- the results of any calculations, analysis, testing or examination referred to above, including, in relation to a substance, any hazardous properties of the substance identified by testing
- any conditions necessary to ensure that the plant, substance or structure is without risks to health and safety when used for a purpose for which it was designed or manufactured or when carrying out any activity discussed in the previous list.

3.1.4 Maintenance of control measures

Measures implemented to control risks presented by identified hazards at a mine must be maintained to ensure their effectiveness under clause 37 of the WHS Regulation, including by ensuring that the control measure is and remains:

- a) fit for purpose
- b) suitable for the nature and duration of the work
- c) installed, set up and used correctly.

3.2 Risk management

A risk management process should be used in designing the person-riding hoists.

The risk management process involves four steps:

- a) **identify hazards** – find out what could cause harm
- b) **assess risks** – understand the nature of the harm that could be caused by the hazard, how serious the harm could be and the likelihood of it happening.
- c) **control risks** – implement any mandatory control measures or the most effective control measure that is reasonably practicable in the circumstances.
- d) **review control measures** – ensure the control measure are working as planned.

Further guidance on risk management and risk assessment is detailed in:

- WorkCover NSW *How to manage work health and safety risks, December 2011*
- AS/NZS ISO 31000:2009 *Risk management - Principles and guidelines*,
- AS/NZS 4024.1201:2014 *Safety of machinery - General principles for design - Risk assessment and risk reduction*, and
- SA/SNZ HB 89:2013 *Risk management - Guidelines on risk assessment techniques*.

An example of typical person-riding hoists operational and maintenance hazards, risks and possible risk controls is provided in Appendix B.

The following diagram illustrates the four steps in the risk management process.

Four step process The following diagram illustrates the four steps in the risk management process.

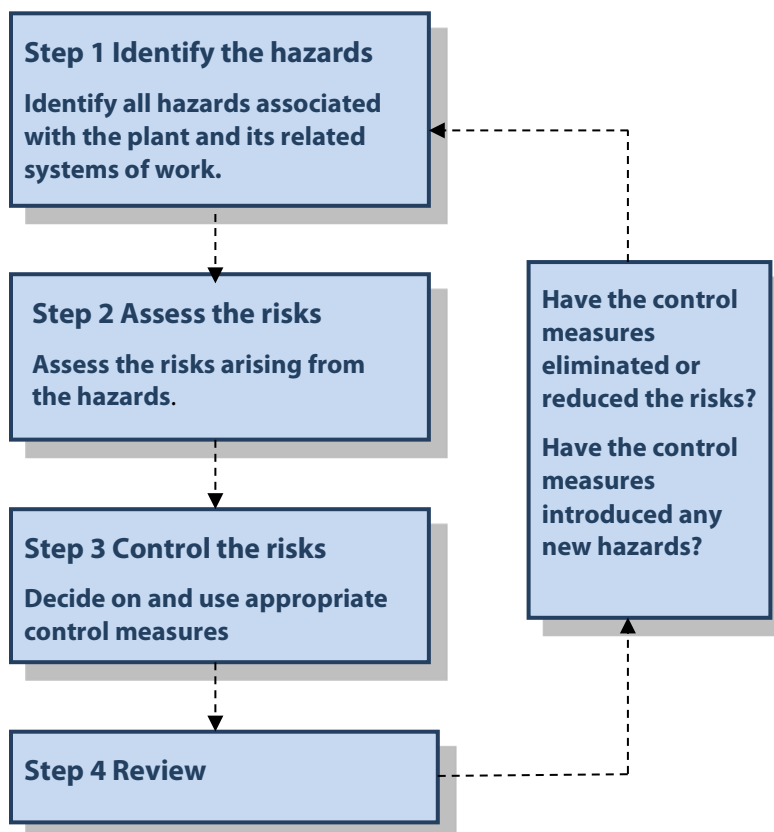

3.3 Hoisting hazards

Hazards present during the entire life cycle of the person-riding hoist system must be identified by the designer.

Hazards typically relate to:

- design of the person-riding hoist
- the way the person-riding hoist is used
- the environment in which the person-riding hoist is used
- the way the person-riding hoist is operated
- the way the person-riding hoist is maintained.

Specific hazards associated with person-riding hoists that must be considered in the design include:

- a) gravity, including:
 - * the conveyance falling out of control.
 - * objects or persons falling down the shaft.
- b) stability of the machine/plant.
- c) mechanical energy, including:
 - * rotating and percussion machinery.
 - * entanglement/entrapment including people being caught between the cage and shaft or shaft gates.

- d) electrical energy.
- e) hydraulic energy.
- f) biomechanical – human error.

3.4 Assessing risks

The design must assess the risks arising from all hazards identified (identify, analyse and evaluate).

This should be a systematic and structured process as follows:

- Determine the possible scenarios—What can happen? When and where? Why and how can it happen?
- Quantify the risk exposure by determining the likelihood and consequence of the scenarios—How likely is this to happen? What are the consequences?
- Prioritise the risk—What risk needs to be addressed first?

The following diagram illustrates this process.

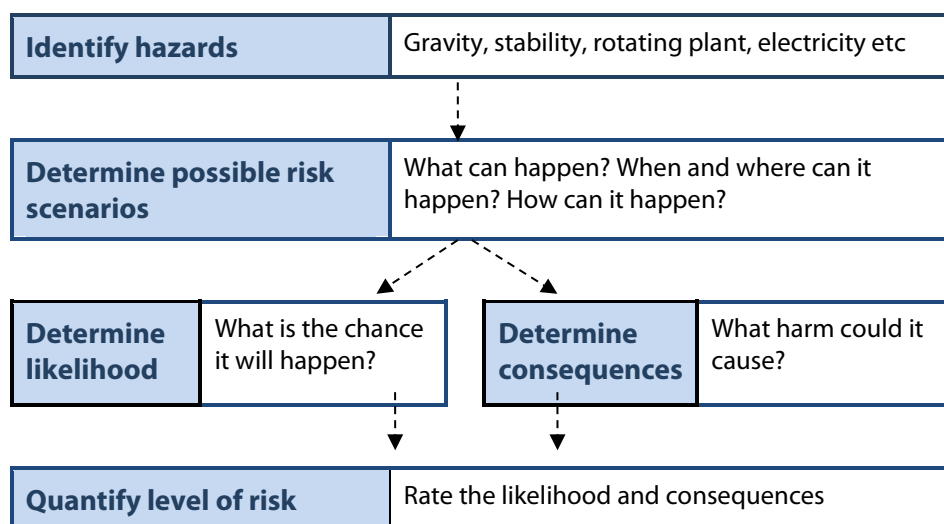

The design risk assessment should consider reasonably foreseeable misuse and should review previous incidents relating to similar plant, where practicable.

Consideration should be given to:

- the risk to health and safety of people in the vicinity that may be affected by the use of the person-riding hoist
- the risk to health and safety of people from the person-riding hoist over its full life cycle, including operation, inspection, testing, maintenance and repair
- human error factors, especially control selection errors and control direction errors, lack of maintenance, lack of competency or knowledge
- inadvertent contact with controls
- change in procedures or the environment
- failure modes, what if something fails?

The designer should consider the possibility of a hazardous situation arising (the likelihood) and the extent of the harm that would result (the consequence). These can be combined to assess the seriousness of the risk. This is illustrated in the following table.

CONSEQUENCES OF AN INCIDENT?	LIKELIHOOD OF AN INCIDENT?			
	Very likely	Likely	Unlikely	Very unlikely
Fatality	HIGH	HIGH	HIGH	MEDIUM
Major injuries	HIGH	HIGH	MEDIUM	MEDIUM
Minor injuries	HIGH	MEDIUM	MEDIUM	LOW
Negligible injuries	MEDIUM	MEDIUM	LOW	LOW

Interpretation

Likelihood could be rated as:

Very likely – could happen frequently

Likely – could happen occasionally

Unlikely – could happen only rarely

Highly unlikely – could happen, but probably never will (care should be taken in judging anything as 'highly unlikely – this should be reserved for rare situations)

Consequences could be rated as:

Fatality

Major injuries – irreversible injury or harm to health

Minor injuries – reversible injury or harm to health needing several days off work

Negligible injuries – first aid

3.5 Controlling risks

Person-riding hoists must be designed so that risks associated with the life cycle of the person-riding hoist are eliminated, or if this is not reasonably practicable, sufficiently controlled. The risk must be controlled to a level as low as reasonably practicable.

Consideration should be given to:

- a) back-up risk controls in the event of a failure of the first control
- b) those risk controls recommended in Appendix B.

The designer must ensure that person-riding hoists are designed:

- a) having regard to ergonomic principles
- b) so that safe access can be gained for maintenance, adjustment, repair and cleaning
- c) so that the build-up of unwanted substances or materials that create a risk is minimised
- d) in the case of plant designed to work near electrical conductors, having regard to such safety requirements as insulation, earthing and appropriate access to controls.

3.5.1 Other risk controls

Any device that prevents access to danger areas must be:

- a) a fixed barrier and interlocked, if access is required during operation, maintenance or for clearing
- b) designed to make by-passing or defeating it, whether deliberately or by accident, as difficult as is reasonably possible
- c) designed to be of solid construction and securely mounted so as to resist impact and shock
- d) is designed so as not to cause a risk itself.

Operational controls must be:

- a) suitably identified on the person-riding hoist so that their nature and function is clear
- b) located so as to be operated readily and conveniently by each person using the person-riding hoist
- c) located or guarded to prevent unintentional activation
- d) able to be locked in the 'off' position (or include an alternative method of power isolation) to enable disconnection of all motive power and forces.

Emergency stop devices must:

- a) be prominent, clearly and durably marked and immediately accessible to each operator of the person-riding hoist
- b) have handles, bars or push buttons that are coloured red
- c) not be able to be affected by electrical or electronic circuit malfunction.

3.6 Safe systems of work and operator competencies

The designer must specify safe systems of work or operator competencies if they are necessary for the safe life cycle use of the person-riding hoist.

3.7 Information

To ensure users understand how to operate the person-riding hoist safely, the designer must provide information on:

- a) any known residual risks and risk control measures provided
- b) the purpose of the person-riding hoist
- c) specific conditions applying to the use of the person-riding hoist
- d) testing or inspections to be carried out on the person-riding hoist
- e) installation, commissioning, operation, maintenance, inspection, cleaning requirements
- f) systems of work for the safe use of the person-riding hoist
- g) emergency procedures.

This information must be supplied to the user/owner. Such information should be relevant to the user in the operation, maintenance and repair of the person-riding hoist.

4 Appendices

Appendix A

Reference documents and definitions

Appendix B

Typical hoist hazards, risks and controls

Appendix C

Good practice for the design of person-riding hoists

Appendix D

Common plant hazards

Appendix E

Feedback sheet

4.1 Appendix A: Reference documents

Some relevant documents that provide additional information include:

- Lightning Ridge Opal Mining Safety Guidelines, 2002
- Minerals Industry Safety Handbook, 2002
- AS 3569 Steel wire ropes - Product specification
- AS 3637.6 Underground mining-Winding suspension equipment. Part 6 Shackles & chains.
- MDG 26 Guideline for examination and discard of mine winder ropes for use in mines.
- AS/NZS 4812 Non-destructive examination and discard criteria for wire ropes in mine winding systems
- AS/NZS ISO 31000:2009: *Risk management - Principles and guidelines*
- S/NZS 4024.1201:2014: *Safety of machinery - General principles for design - Risk assessment and risk reduction*
- SA/SNZ HB 89:2013: *Risk management - Guidelines on risk assessment techniques*
- WorkCover NSW *How to manage work health and safety risks, December 2011*

4.2 Appendix B: Typical hoisting hazards, risks and controls

This table shows some possible hazards, risk scenarios and risk controls. It is not intended as complete list of all hazards, risk scenarios and risk controls.

Hazard	Risk scenario	Possible risk controls
Gravity Conveyance falling out of control	<i>Control circuit failure</i> causing an unintended activation of conveyance, due to: <ul style="list-style-type: none"> • Electrical control malfunction • Hydraulic control malfunction • Pneumatic control malfunction 	<ul style="list-style-type: none"> • Fit for purpose control components • Control circuits with sufficient integrity and/or redundancy for the risk being controlled. • Appropriate or Category or safety integrity levels on the safety control circuits • Redundancy of critical control devices • Emergency stops • Emergency conveyance arrest device • Competent people • Regular inspection & testing of safety critical components, see MDG 42.2 • Good maintenance of safety critical components, see MDG 42.2
	<i>Rope break</i> causing the conveyance to free fall, caused by: <ul style="list-style-type: none"> • Corrosion, • Broken or loose wires, • Physical rope damage, • Kinks or distortion of rope, • Rubbing or deformation of rope. • Sheave damage • Sheave too narrow 	<ul style="list-style-type: none"> • Factor of safety of 10:1 on rope when new • Emergency conveyance arrest device • Regular rope inspections & tests • Use of lubrication on rope • Good maintenance of ropes, see MDG 42.2. • Sheave maintenance
	<i>Rope connections failure</i> allowing the cage/platform to free fall, caused by: <ul style="list-style-type: none"> • Rope clamps fitted the wrong way, • Rope clamps too loose, • Threads stripped, • Rope slipping through the clamps, • Fatigue of rope clamps 	<ul style="list-style-type: none"> • Factor of safety of 10:1 on rope when new • Emergency conveyance arrest device • Physical examination of rope connections • Periodic checking of rope clamp bolts • Good maintenance, see MDG 42.2.
	<i>Brake failure</i> or brake will not hold load allowing the conveyance to free fall caused by <ul style="list-style-type: none"> • Contamination of brake path • Worn brake pads • Incorrect adjustment of brake • Loose brake components 	<ul style="list-style-type: none"> • Brake inspections (See MDG 42.2 Maintenance. Section 4.8 Brakes) • Emergency conveyance arrest device • Good maintenance see MDG 42.2 • Periodic testing of braking system

Hazard	Risk scenario	Possible risk controls
Gravity Conveyance falling out of control <i>(continued)</i>	<i> Holding means or other drive failure (other than brake) allowing the conveyance to free fall caused by</i> <ul style="list-style-type: none"> • Failure of the gearbox • Failure of drive coupling(s) • Failure of holding device 	<ul style="list-style-type: none"> • Factor of safety on drive • Inspections of gearbox • Inspections of couplings • Inspections of belts and drive chains • Hoist maintenance – See MDG 42.2 • Emergency conveyance arrest device • Good maintenance
	<i> Broken rope emergency arresting device fails to operate in an emergency allowing the cage / platform to fall to the shaft bottom</i> <ul style="list-style-type: none"> • Seized components. • Broken welds or components • Missing bolts • Broken or missing springs 	<ul style="list-style-type: none"> • Good maintenance see MDG 42.2 • Daily inspections • Regular testing
Gravity Objects or persons falling down the shaft	<i> Cage / Platform Loose bolts or broken welds.</i> <ul style="list-style-type: none"> • Cage/Platform breaks apart and operator falls 	<ul style="list-style-type: none"> • Good maintenance see MDG 42.2 • Daily inspections • Regular testing
	<i> Cage / Platform Floor rusted or timber rotted.</i> <ul style="list-style-type: none"> • Operator falls through floor. Possible injury or death. 	<ul style="list-style-type: none"> • Good maintenance see MDG 42.2 • Daily inspections
	<i> Sheave Hoist fitted with a sheave attached to the head frame by a swivel hook. There is no safety catch on the swivel hook</i> <ul style="list-style-type: none"> • Sheave becomes detached from head frame. Sheave falls down shaft and hits person riding hoist. Possible injury or death. • Sheave becomes detached from head frame rope, free falls then takes up slack and jerks to a stop. Rope break and / or structural failure. 	<ul style="list-style-type: none"> • Fit for purpose equipment • Good maintenance see MDG 42.2
	<i> Head Frame has no fences or gates on the surface, leaving an open hole when the cage is at shaft bottom</i> <ul style="list-style-type: none"> • Person comes too close and falls down the shaft. • Person trips or steps back • Person is standing under an open hole and an object falls from above. 	<ul style="list-style-type: none"> • Fences and gates fitted • Good design • Regular inspections and maintenance • Good maintenance see MDG 42.2
	Risk Scenario	<i>Possible Risk Controls</i>

	<p>Head frame failure causing a collapse of the structure caused by</p> <ul style="list-style-type: none"> • Loose bolts and/or broken welds • Physical damage • Corrosion or fatigue • Not securely anchored <p>A bolt, nut or a piece of the frame comes loose and falls down the shaft striking a person on the cage.</p>	<ul style="list-style-type: none"> • <i>Good design</i> • <i>Regular inspections and testing</i> • <i>Good maintenance see MDG 42.2</i>
	<p>Winch mounting fails allowing the winch to be pulled into the head sheave or fall down the shaft caused by</p> <ul style="list-style-type: none"> • loose bolts and/or broken welds • physical damage • corrosion or fatigue 	<ul style="list-style-type: none"> • <i>Good design</i> • <i>Regular inspections and testing</i> • <i>Good maintenance see MDG 42.2</i>
	<p>Entanglement with moving parts belts, drive chains, sprockets and couplings, rope and sheave caused by</p> <ul style="list-style-type: none"> • Guards missing • Broken guards • Insecure guards • Weak guards 	<ul style="list-style-type: none"> • <i>Good design</i> • <i>Fit for purpose guarding, no moving part being able to be touched</i> • <i>Regular inspections</i> • <i>Good maintenance see MDG 42.2</i>
	<p>Electric shock cause by direct contact</p> <ul style="list-style-type: none"> • Cover left off • Broken cover • Inappropriate housing • Damage to electrical equipment / cables 	<ul style="list-style-type: none"> • <i>Fit for purpose equipment,</i> • <i>Consider relevant parts of AS 3000</i> • <i>Good maintenance practices</i> • <i>Licensed electricians (competent people)</i> • <i>Lightning ridge document (CH11)</i>
	<p>Electric shock cause by indirect contact</p> <ul style="list-style-type: none"> • Moisture ingress • Failure of insulation of electrical equipment and cables 	<ul style="list-style-type: none"> • <i>Fit for purpose equipment,</i> • <i>Consider relevant parts of AS 3000</i> • <i>Good maintenance practices</i> • <i>Licensed electricians (competent people)</i> • <i>Lightning ridge document (CH11)</i> • <i>Electrical protection (such as earth leakage, overloads, short circuit,)</i>

	Fire initiated by electrical energy	<ul style="list-style-type: none"> • <i>Good maintenance practices</i> • <i>Licensed electricians (competent people)</i> • <i>Lightning ridge document (CH11)</i> • <i>Electrical protection (such as earth leakage, overloads, short circuit,)</i>
	Risk Scenario	<i>Possible Risk Controls</i>
	Hydraulic Drive Blown or loose hose or component <ul style="list-style-type: none"> • Hydraulic oil under pressure sprayed to atmosphere. Oil injection. • Possible free fall of cage and due to not enough resistance from oil left in the system the emergency arresting system does not activate 	<ul style="list-style-type: none"> • <i>Good maintenance practices see MDG 42.2</i> • <i>Regular inspections</i> • <i>Regular testing</i>
	Pneumatic drive Hose not connected with safety clip <ul style="list-style-type: none"> • Hose comes apart and whips around. • Loss of drive and cage free falls 	<ul style="list-style-type: none"> • <i>Good maintenance practices see MDG 42.2</i> • <i>Regular inspections</i> • <i>Regular testing</i>
	Pneumatic drive Hose damaged and blows out <ul style="list-style-type: none"> • Air blows out under pressure resulting in possible injury from direct contact with the stream of air or dust blows up and inflicts an eye injury • Loss of drive and cage free falls 	<ul style="list-style-type: none"> • <i>Good maintenance practices see MDG 42.2</i> • <i>Regular inspections</i> • <i>Regular testing</i>

4.3 Appendix C: Good practice for design of person-riding hoists

This section provides a summary of additional good engineering practice that should be considered when designing person-riding hoists for use in small gemstone mines. A risk assessment process should be used when considering these requirements.

4.3.1 General

- a) Only power-operated hoists should be used for person-riding.
- b) Any springs used in the design of the person-riding hoist should be of the compression type.
- c) The shaft top gates should have a mechanism that prevents the gate opening unless the cage is in the correct position.

4.3.2 The person-riding hoist winch

4.3.2.1 Brakes

- a) The braking system should be fitted to the drum. It should be a disc type brake.
- b) Preference should be given to the use of two independent brake systems.
- c) The braking system should fail to the on position in the event of loss of power.
- d) The brakes should be applied by a mechanical device.
- e) The brakes should be protected from water and other contaminants that could reduce the brake stopping or holding ability.
- f) Screwed components of brake systems should not be externally loaded in tension unless they have a factor of safety of at least 15 to 1.

4.3.2.2 Drum drive system

- a) The maximum rope tension developed by the drive system should not be capable of breaking the person-riding hoist rope under any condition of operation, including accidental jamming of the cage/platform.
- b) A factor of safety of at least 2.5 should exist between the maximum rope tension developed by the drive under abnormal dynamic conditions and the breaking strength of the rope in use.
- c) A clutch should not be fitted to any rope drum drive system used for person-riding.

4.3.2.3 Drum

- a) The person-riding hoist drum should be designed for the total load to be hoisted with a factor of safety of 10 and have flanges at both ends.
- b) The top layer of the rope should not be closer than 50mm to the flange tips when the drum is grooved, or 63 mm where the drum is smooth, as shown next page.

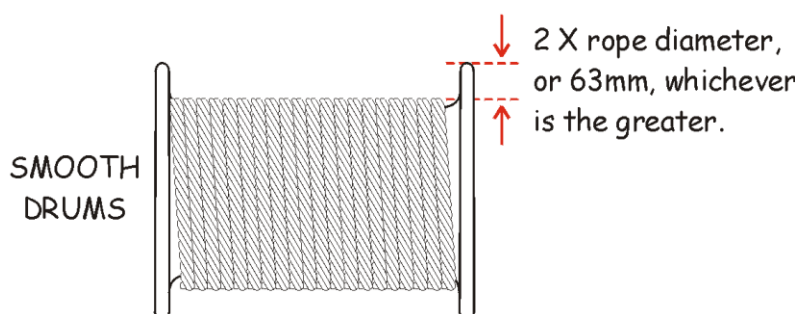
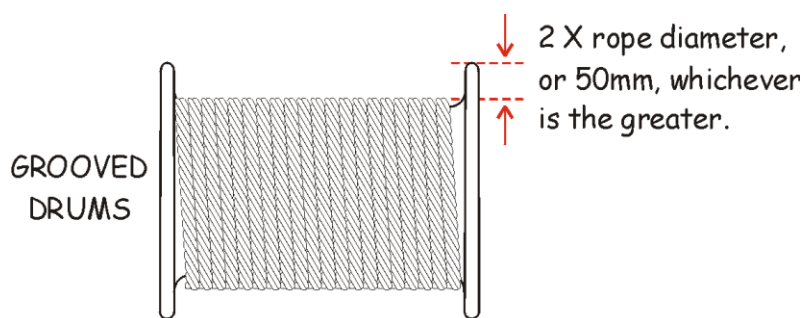

- c) At least three full wraps of rope should remain on the drum when the cage/platform is at the bottom of the shaft. More wraps should be provided to allow for periodic re-anchoring of the rope at both rope drum and cage/platform ends.
- d) The minimum diameter of the drum should be 150 mm or greater as recommendations by the rope manufacturer.
- e) The number of wraps across the width of the drum is calculated as drum width divided by Rope diameter + 4%.

For example:

If drum width is 150 mm and rope width is 10 mm, we have:

$$150 / (10 \times 1.04) = 14 \text{ rounded down to give the number of full wraps.}$$

Similarly, for the same rope on wider drums, rounded down to give the number of full wraps

$$200 \text{ mm} / 10.4 \text{ mm} = 19$$

$$300 \text{ mm} / 10.4 \text{ mm} = 28$$

$$400 \text{ mm} / 10.4 \text{ mm} = 38.$$



Note: Guarding has been removed for clarity.

The following table gives rope length capacities for drums with a 150 mm diameter.

Drum width (mm)	Flange depth (mm)	Number of rope layers	Rope length (m)
150	70	2	14
200	70	2	19
300	70	2	26
400	70	2	38
150	83	3	22
200	83	3	30
300	83	3	39
400	83	3	60

4.3.3 Ropes

- The minimum rope diameter should be 8 mm for a single person and 10 mm for 2 people. The rope must have a factor of safety of 10:1.
- The person-riding hoist rope should be galvanised steel wire rope, 6*24 construction, fibre core and grade 1570 MPa, 8 mm minimum diameter for a single person hoist and 10 mm in diameter minimum for a 2 person hoist.
- A copy of the rope manufacturing test certificate should be provided with the rope upon purchase. The certificate should include information on construction, grade and tensile strength.
- The drum end of the rope should be anchored by a clamp securely attached to the drum and clear of the rope windings.
- The cage/platform end of the rope should have a reliable rope end connection, such as a thimble, and be clamped securely with a minimum of 3 grips at a minimum spacing of 50mm (see next page).

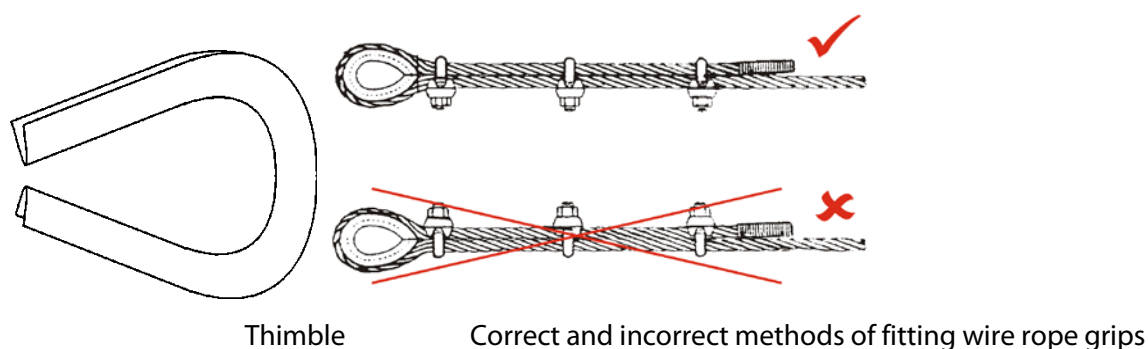

4.3.4 Sheave wheels

- A sheave, if used in the design of the person-riding hoist, should be rated for the load to be lifted and the power developed by the winch. Generally the safe working load is marked on the side of the sheave. The shaft should be purchased with the sheave.
- The diameter of the sheave wheel should be equal to or larger than the diameter of the drive drum.
- The minimum sheave wheel diameter should be 150 mm for a hoist having a drum diameter of 150 mm.

Note: This is based on a maximum speed of 0.6 m/s using a 6*24 steel wire rope.

- The sheave rope groove radius should be the radius of the rope plus 5%.
- The sheave must incorporate a method of retention to prevent the rope from leaving the sheave groove. The clearance between the rope and the method of retention must be a practical minimum to stop the rope coming off the sheave.
- The sheave shaft bolts should be positively prevented from working loose and have a factor of safety of at least 10 to 1 unless they are in tension in which case the factor of safety should be 15 to 1.

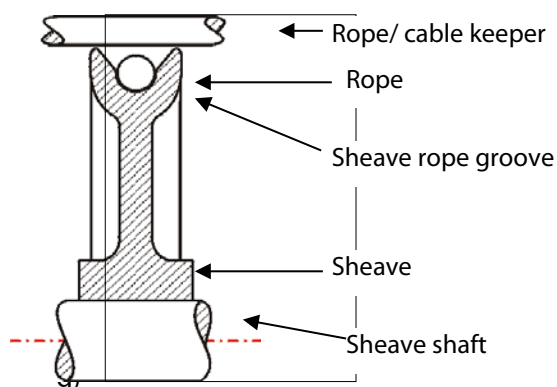

4.3.5 Cage/platform

- A mechanism should be fitted to the cage so that in the event of a rope failure the cage/platform, with its maximum rated payload, will be automatically brought to rest safely. The system must operate quickly enough to prevent injury from falling too far. The system should be able to operate without failure when exposed to any impact loads generated or the loads generated by high deceleration rates of the cage/platform
- The cage/platform should be attached to the rope by means of a shackle or other suitable device that is fixed to a king bar that is bolted to the cage/platform. The shackle pins should be positively retained to prevent them from becoming loose.
- There should be falling object protection for persons in the cage. Consideration should be given to providing a means for people to escape.

4.3.6 Controls

- a) The cage/platform operating lever or button should automatically return to the off position when released, i.e. designed with “dead man” control principles.
- b) Call control stations should be located on the surface, the shaft bottom and any other working level.
- c) The cage/platform control should have a release switch to enable it to be called from the surface or shaft bottom when not being used.
- d) The control system can be electric, hydraulic, pneumatic or mechanically operated.
- e) An emergency stop should be located at the shaft bottom.
- f) The emergency stop should be a separate circuit and lock out after being operated.
- g) There should be automatic devices (e.g. limit switches) located on the surface and at shaft bottom to automatically control the stopping of the person-riding hoist at those locations. This should be independent to that of the cage/platform control.
- h) In addition to these automatic devices (limit switches) there should be over-travel devices or lockout switches, etc so that power is cut off in the event of an over wind. The over travel devices should be connected into the safety circuit and upon operation should cause the person-riding hoist to be brought safely to a stop.
- i) Physical over travel devices should be located at the top of the shaft and at the bottom of the shaft and installed so as to prevent injury to personnel and damage to the cage/platform and/or damage to the person-riding hoist mechanism when operated.
- j) The person-riding hoist control system should be provided with a hoist control circuit and a separate hoist safety circuit. The control system should be assessed for the appropriate Category level, refer AS 4024.1501 or safety integrity level (SIL), refer AS 62061 Safety of machinery - Functional safety of safety-related electrical, electronic and programmable electronic control system, unless the design risk assessment establishes otherwise.
- k) A safe means of recovery from an overwind condition should be provided.

4.3.7 Head frame/shaft guides

- a) The sheave wheel should be fixed high enough in the head frame so that the rope connections do not go over the sheave wheel when the cage/platform is at the surface
- b) The person-riding hoist drum, when mounted in the head frame (top of head frame or at ground level), should be securely mounted and the mountings should be able to withstand the maximum pull the drive system can place on the person-riding hoist drum under dynamic and or drive stall conditions
- c) The head frame should be positioned so that the rope coming off the drum or sheave wheel is directly above the line of travel of the cage/platform.
- d) Shaft guides should be sufficiently straight so that the person-riding hoist rope will never rub on the shaft guides or any other stationary steelwork.
- e) The shaft guides should be able to withstand the forces involved in stopping a runaway cage at any position in the shaft.
- f) The shaft guides should be designed and maintained so the cage/platform can move up without excessive increase in load from poorly fitting guides. In addition the guides should not excessively hinder the downward movement of the cage/platform because intermittent slack hoist rope needs to be prevented.
- g) The centre of the person-riding hoist drum (half way between the flanges) should be on the centre line of the sheave (in the same plane as the sheave) and the maximum fleet angle should be 3° as shown below.

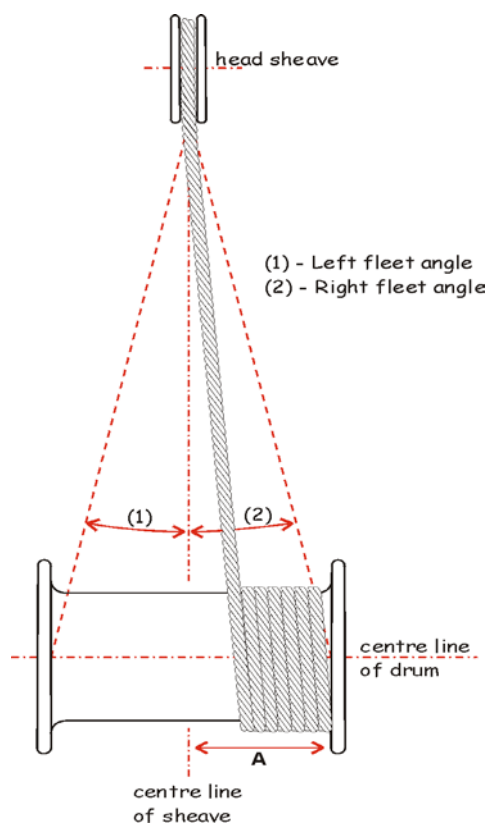

Examples of minimum rope length between the sheave had the drum with a maximum 3° fleet angle.

Drum width (mm)	Minimum distance between sheave and drum (mm)
300	2862
200	1908
150	1431

4.3.8 Landings

- Appropriate landings should be provided at the top and bottom of the shaft and any intermediate access points.
- Landings should have appropriate means to prevent a moving cage/platform injuring people or people falling down the shaft e.g. gates/fences, guards.

4.3.9 Electrically operated hoists

In addition to the above, the following apply to electrically operated hoists:

- The enclosures of the person-riding hoist motor and associated electrical apparatus should be designed to suit the environment in which they are operating. This should be a minimum of IP 54.
- Limit switches, emergency stops and other control or safety devices should operate at extra Low Voltage (refer AS/NZS 3000).
- The power circuit for remote or pendant control devices should not exceed extra low voltage.
- The safety circuit should be able to perform its function before the person-riding hoist motor is energised.

- e) Typically the safety circuit should include all safety functions identified in the design risk assessment. These should include: emergency stop, dead-man, top and bottom travel limits, gate interlocks and any other safety devices.
- f) The safety circuit should be designed with 'fail to safety' principles and upon loss of the incoming power supply or operation of any device located within the safety circuit, the circuit should 'lock out', causing the person-riding hoist brakes to apply (if applicable) and bring the person-riding hoist to rest.
- g) The safety circuit should have reset facilities on the surface.

4.4 Appendix D: Common plant hazards

Energy source	Hazard	Consequences for people
Bio-mechanical	Ergonomic design failure	<ul style="list-style-type: none"> Excessive effort Human error, human behaviour Injuries from not using PPE Slips, trips, falls Sprains, strains Unhealthy posture
Chemical	<ul style="list-style-type: none"> Dust Explosion Fires Fluids Fumes Gases Mists 	<ul style="list-style-type: none"> Asphyxiation Burn injuries Cancer Dust Irritation Lung damage Poisoning
Electricity	<ul style="list-style-type: none"> Electric shock Electric burns Fire 	<ul style="list-style-type: none"> Electrocution Burns, scald injuries Asphyxiation
Gravity	Stored potential energy – weight in elevated machine components	<ul style="list-style-type: none"> Crush injuries Fall injuries
Mechanical	<ul style="list-style-type: none"> Crushing Drawing-in or trapping Entanglement Friction or abrasion Impact Shearing Stored potential energy – springs Unexpected movement 	<ul style="list-style-type: none"> Amputations Crush injuries Entanglement injuries Impact injuries
Noise	Excessive noise levels	<ul style="list-style-type: none"> Hearing loss Commit errors Not hear alarms or acoustic signals Tinnitus
Pressure	Stored potential energy – liquids and gases under pressure	<ul style="list-style-type: none"> Fluid injection injuries Struck by ejected projectiles

Energy source	Hazard	People consequence
Temperature	<ul style="list-style-type: none">• Contact with objects at extreme high or low temperatures• Explosions• Flames• Heat radiation• Hot or cold work environment	<ul style="list-style-type: none">• Burns, scalds• Cancer• Freezing• Heat stress• Hypothermia
Vibration	Hand held machine vibration	<ul style="list-style-type: none">• Neurological, vascular disorders• Whole body vibration damage

4.5 Appendix E – Registration of Person-Riding Hoists (Winding Systems) in Small Gemstone Mines Design Order 2015

Registration of Person-Riding Hoists (Winding Systems) in Small Gemstone Mines Design Order 2015.

www.resourcesandenergy.nsw.gov.au/__data/assets/pdf_file/0011/576704/Design-order-for-registration-of-person-riding-hoists-in-small-gemstone-mines.pdf

Government Notices

Mining and Petroleum Notices

REGISTRATION OF PERSON-RIDING HOISTS (WINDING SYSTEMS) IN SMALL GEMSTONE MINES DESIGN ORDER 2015

under the

WORK HEALTH AND SAFETY (MINES) REGULATION 2014

I, Douglas Revette, Executive Director Governance, with the delegated authority of the Secretary, Department of Industry, Skills and Regional Development in pursuance of clause 177 (5) of the *Work Health and Safety (Mines) Regulation 2014* ("the Regulation") make the following Order.

Dated this 17th day of August 2015.

DOUGLAS REVETTE
Executive Director Governance
Department of Industry, Skills and Regional Development

Explanatory note

This Order does not apply to winding systems (other than person-riding hoists in small gemstone mines).

REGISTRATION OF PERSON-RIDING HOISTS (WINDING SYSTEMS) IN SMALL GEMSTONE MINES DESIGN ORDER 2015

under the

WORK HEALTH AND SAFETY (MINES) REGULATION 2014

Name of Order

This Order is the *Registration of Person-Riding Hoists (Winding Systems) in Small Gemstone Mines Design Order 2015*.

Commencement

This Order commences on 17th August 2015.

Interpretation

In this Order:

MDG is a reference to mining design guidelines produced by the NSW Government and published on the Department of Industry, Skills and Regional Development website.

person-riding hoists means a winding system used in an underground mine, that is a small gemstone mine, where the winding system lifts no more than 40 metres from the surface of the small gemstone mine to the underground workings and carries no more than two people.

Regulation means the *Work Health and Safety (Mines) Regulation 2014*.

small gemstone mine means a gemstone mine (including an opal mine) that has less than five workers, as defined in clause 3 of the Regulation.

winding system means any plant (other than a portable winch or plant that is manually operated) that is used in a shaft to lift a person to or from an underground mine or between levels in an underground mine (regardless of whether it is used exclusively for that purpose), as defined in clause 3 of the Regulation.

winding systems other than person-riding hoists means winding systems excluding person-riding hoists.

Design requirements – person-riding hoists

All person-riding hoists must be designed in accordance with section 2 of MDG 42.1 *Guideline for person-riding hoists (winding systems) in small gemstone mines Part 1: Design*, as amended from time to time.

Testing requirements

All person-riding hoists must be tested in accordance with section 2.7 of MDG 42.1, as amended from time to time.

Performance standards

All person-riding hoists must comply with the performance requirements set out in section 2 of MDG 42.1, as amended from time to time.